

CARTEN™

MM210 RC CAR MM210R INSTRUCTION MANUAL

M-CHASSIS

1/10 EP RC M-Chassis Kit

4WD SHAFT
DRIVEN

WWW.CARTEN-RC.COM

CAUTION

Notice: Thank you for choosing the carten M-CHASSIS M210 M210R
The following items are needed for completion of the KIT, They are not included with this kit (unless noted), and should be obtained from your local hobby shop.
Be sure to read the instructions completely prior to assembly.

Tools needed To Assemble

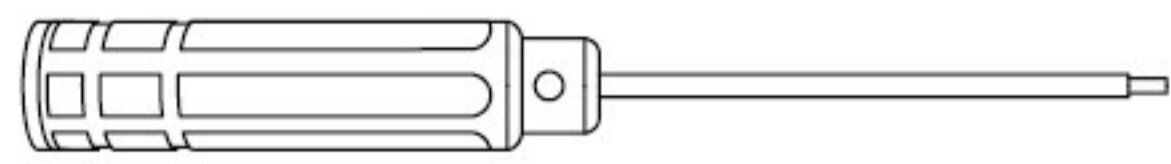

Hex Wrenches(1.5mm / 2.0mm / 2.5mm)

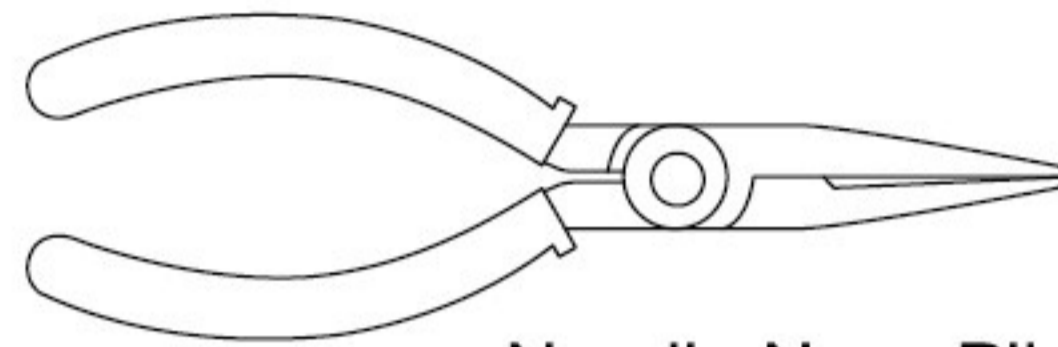

Needle Nose Pliers



CA Glue

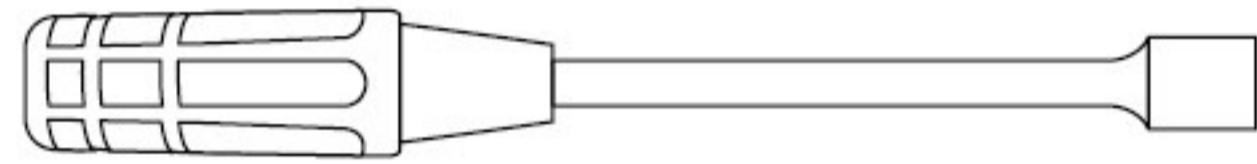

Box Wrench(5.5mm / 7mm / 10mm)

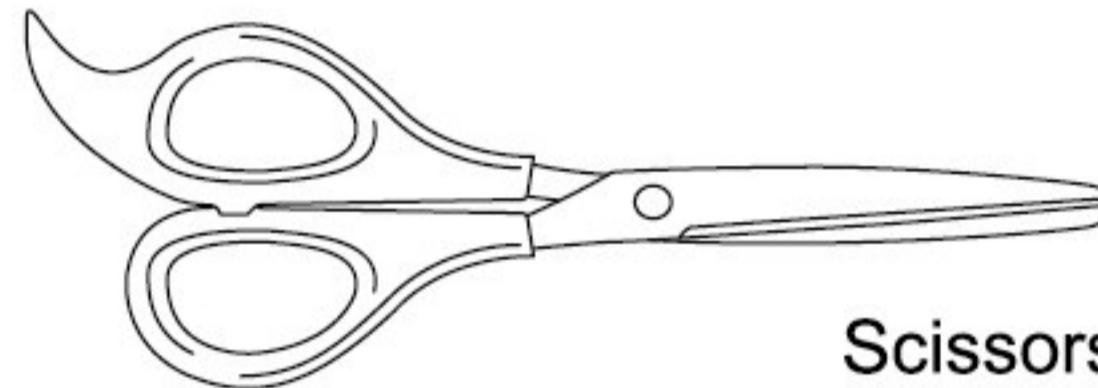

Scissors



Thread Locker

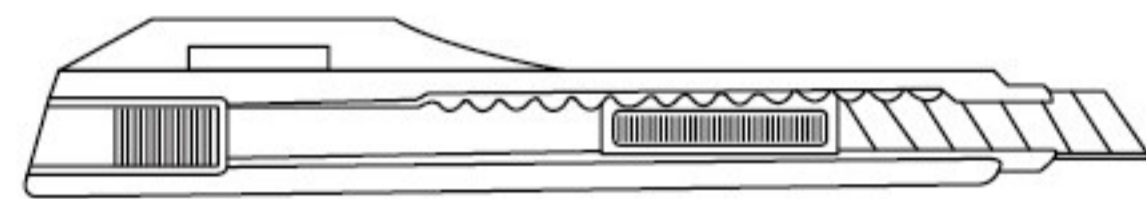

Hobby Knife



Tape

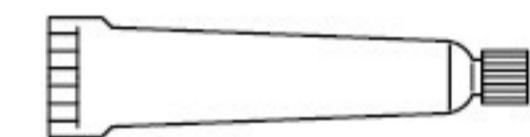

Rubber Glue

Items Needed To Control Car

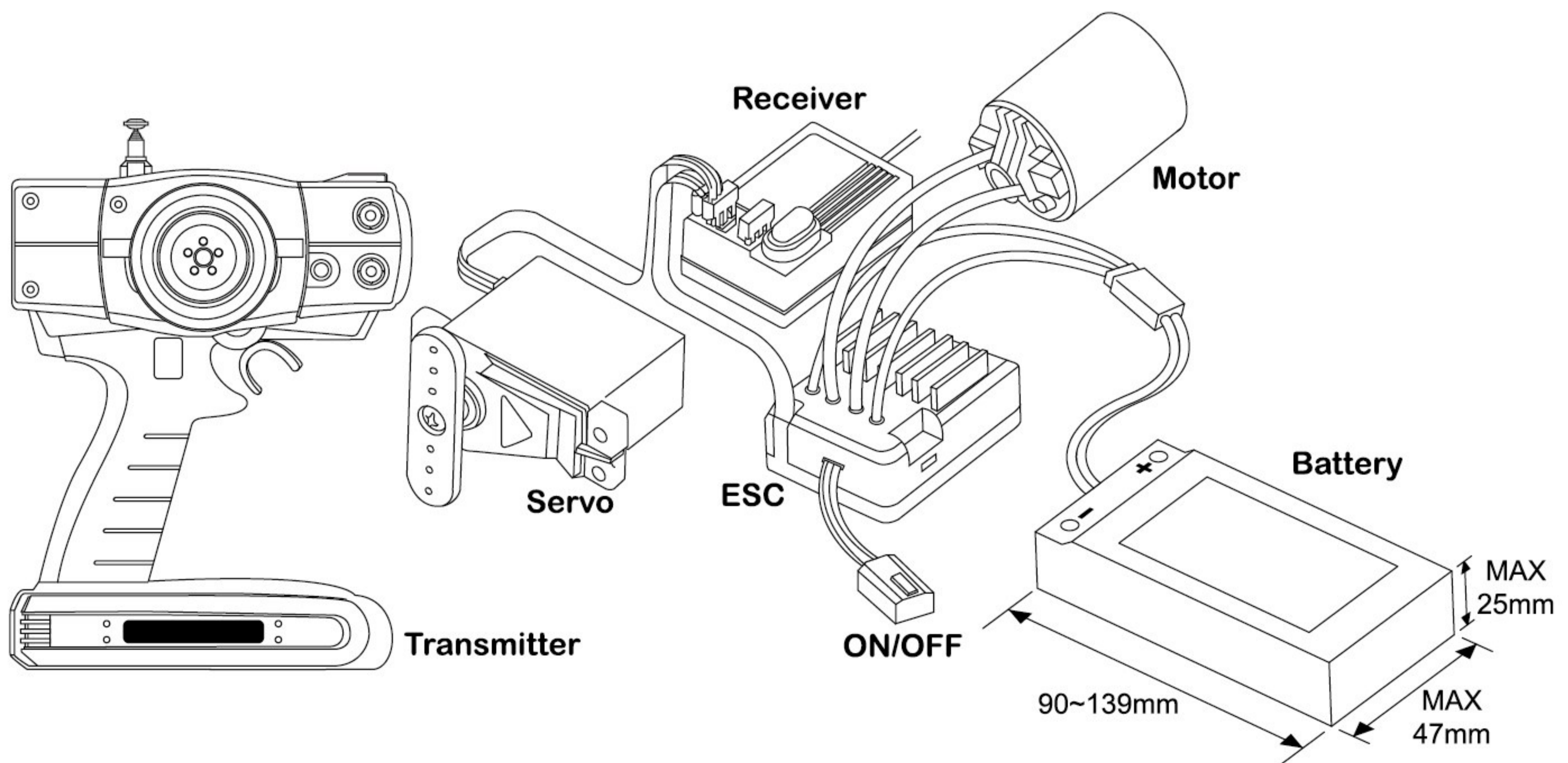

CARTEN M210 EP 1/10 M – CHASSIS

M210 Specification

DRIVETRAIN	Shaft Drive 4WD
Track Width	166mm
Wheelbase	208-210mm
Final Gear Ratio	2.35 (40/17)
Gear Ratio	5.46
Tire Diameter	55mm

Equipped

Full Bearing	Aluminum Center Driver Shaft
Steel CVD Drive Shaft	Aluminum Spur Gear Hub
Carbon Composite Fibre Chassis, Upper Deck, Shock Tower	Oil Shocks
Aluminum Motor Mount	Ball Differential

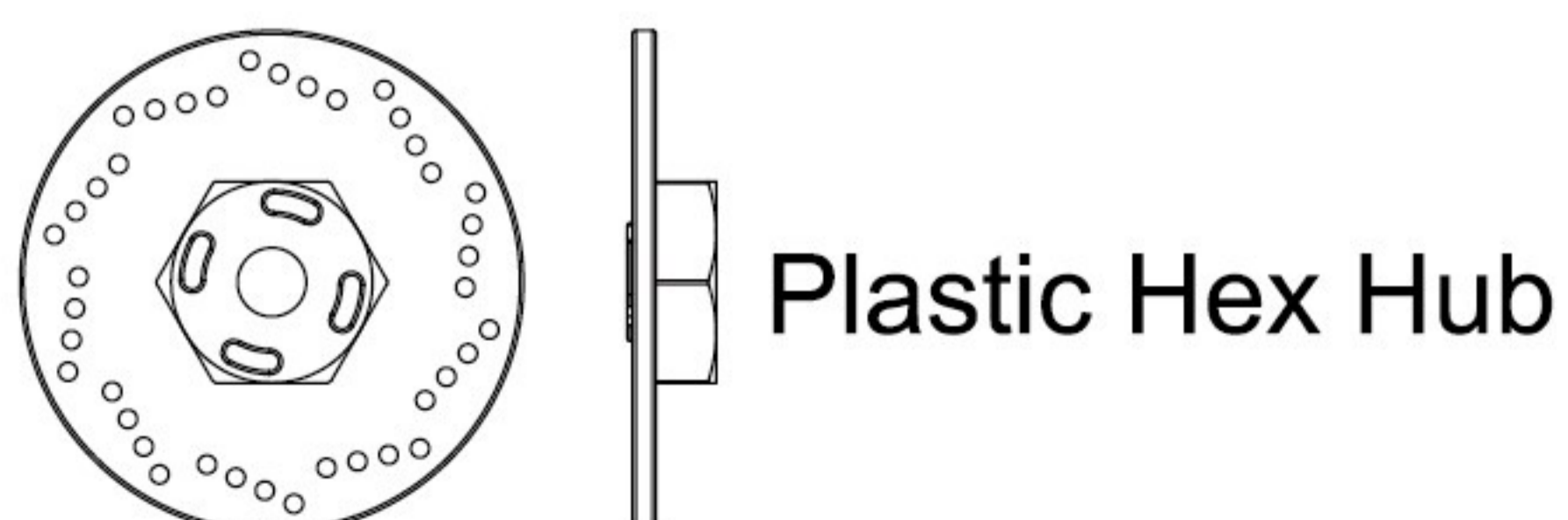
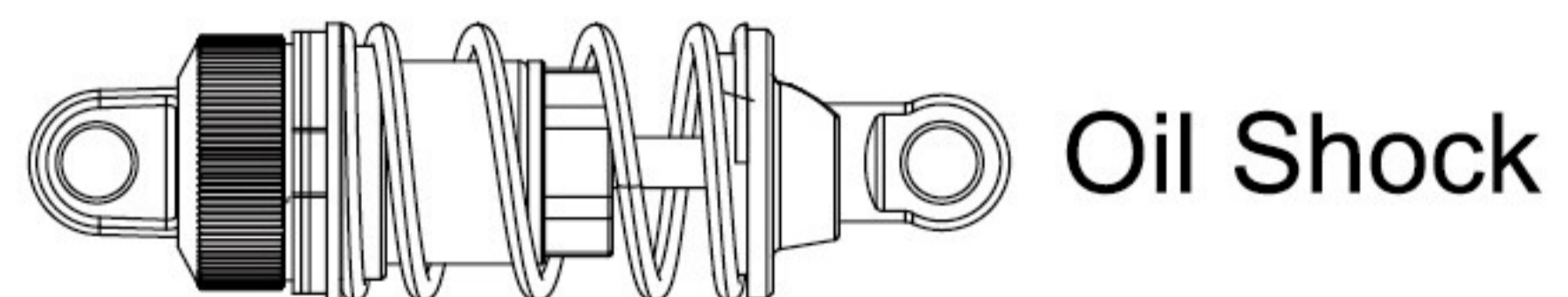
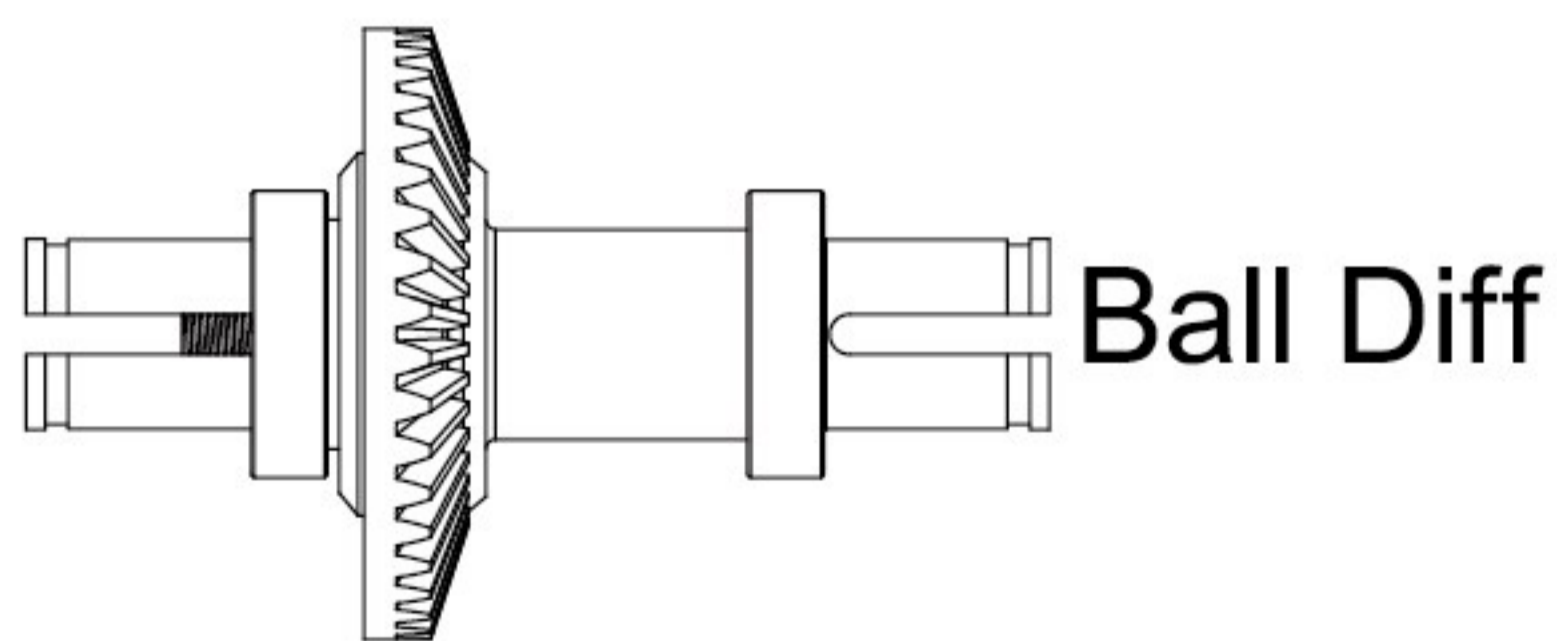

CARTEN M210-R EP 1/10 M – CHASSIS

M210-R Specification	
DRIVETRAIN	Shaft Drive 4WD
Track Width	166mm
Wheelbase	208-210mm
Final Gear Ratio	2.47 (42/17)
Gear Ratio	4.56
Tire Diameter	55mm

Equipped	
Full Bearing	Aluminum Spur Gear Hub
Steel CVD Drive Shaft	Aluminum 12mm Hex Hub
Carbon Composite Fibre Chassis , Upper Deck , Shock Tower	Aluminum Shocks
Aluminum Motor Mount	Metal Gear Differential
Aluminum Center Driver Shaft	Full Turnbuckle

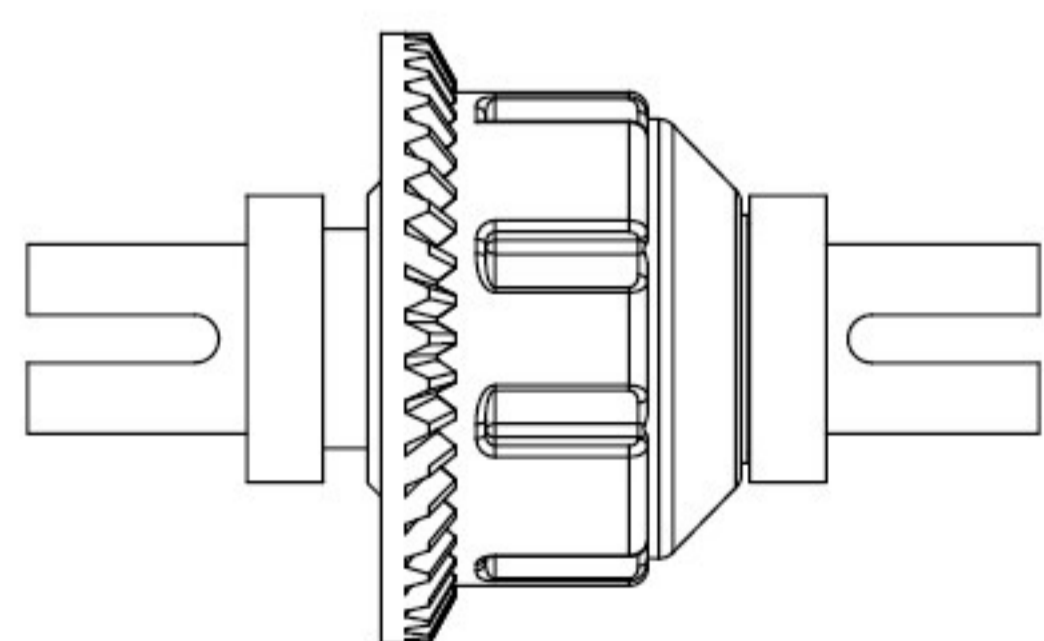

Metal Gear Diff



Aluminum Hex Hub

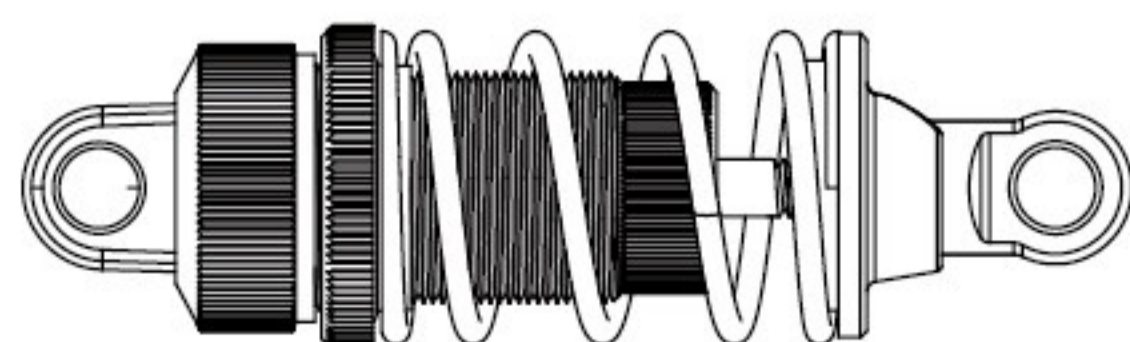

Aluminum Shock



Turnbuckle

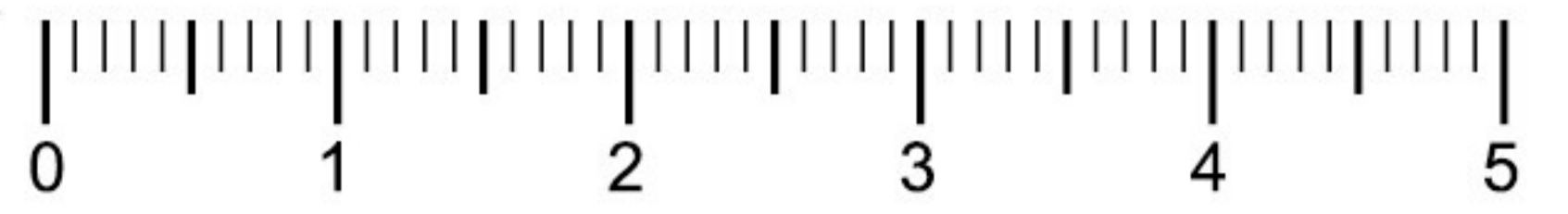

GEAR DIFF

1

-  X2
NBA235 5.1×9×0.5mm
-  X2
NBA235 5.1×9×0.2mm
-  X2
NBA235 4×9×0.5mm
-  X2
NBA303 4.0mm
-  X4
NBA286 M2×8mm
-  X2
NBA299 10×15×4mm

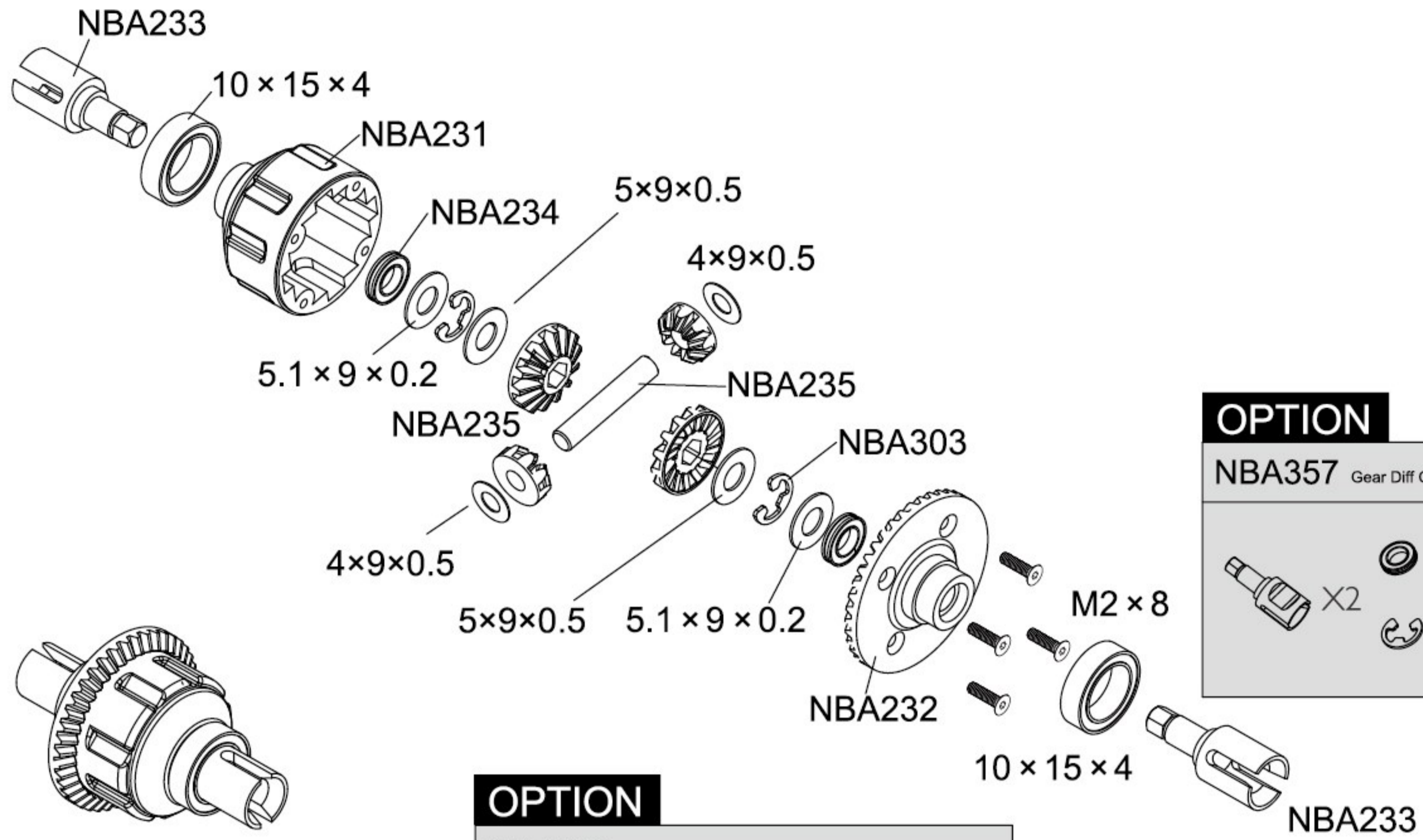

OPTION

NBA357 Gear Diff Cup Joint(Heavy Duty)



OPTION



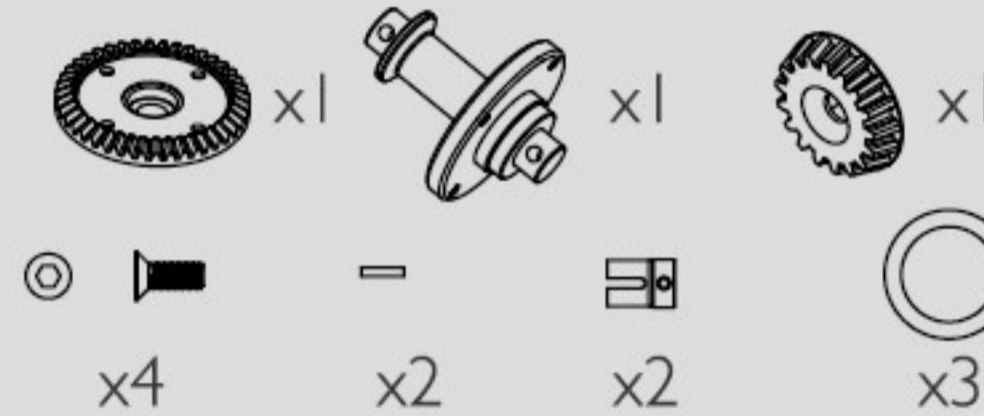





NBA323 Solid Axle(42T/17T Metal)



NBA230 #5,000 Diff Oil X2

BALL DIFF

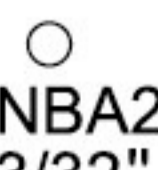
2

-  X1
NBA236
-  X1
NBA240 2.6×6×3mm
-  X2
NBA297 5×8×2.5mm
-  X2
NBA299 10×15×4mm
-  X1
NBA238 M2.5×22mm
-  X1
NBA238 M2.5
-  X12
NBA237 3/32"
-  NBA236 2.7×5.9×0.5mm

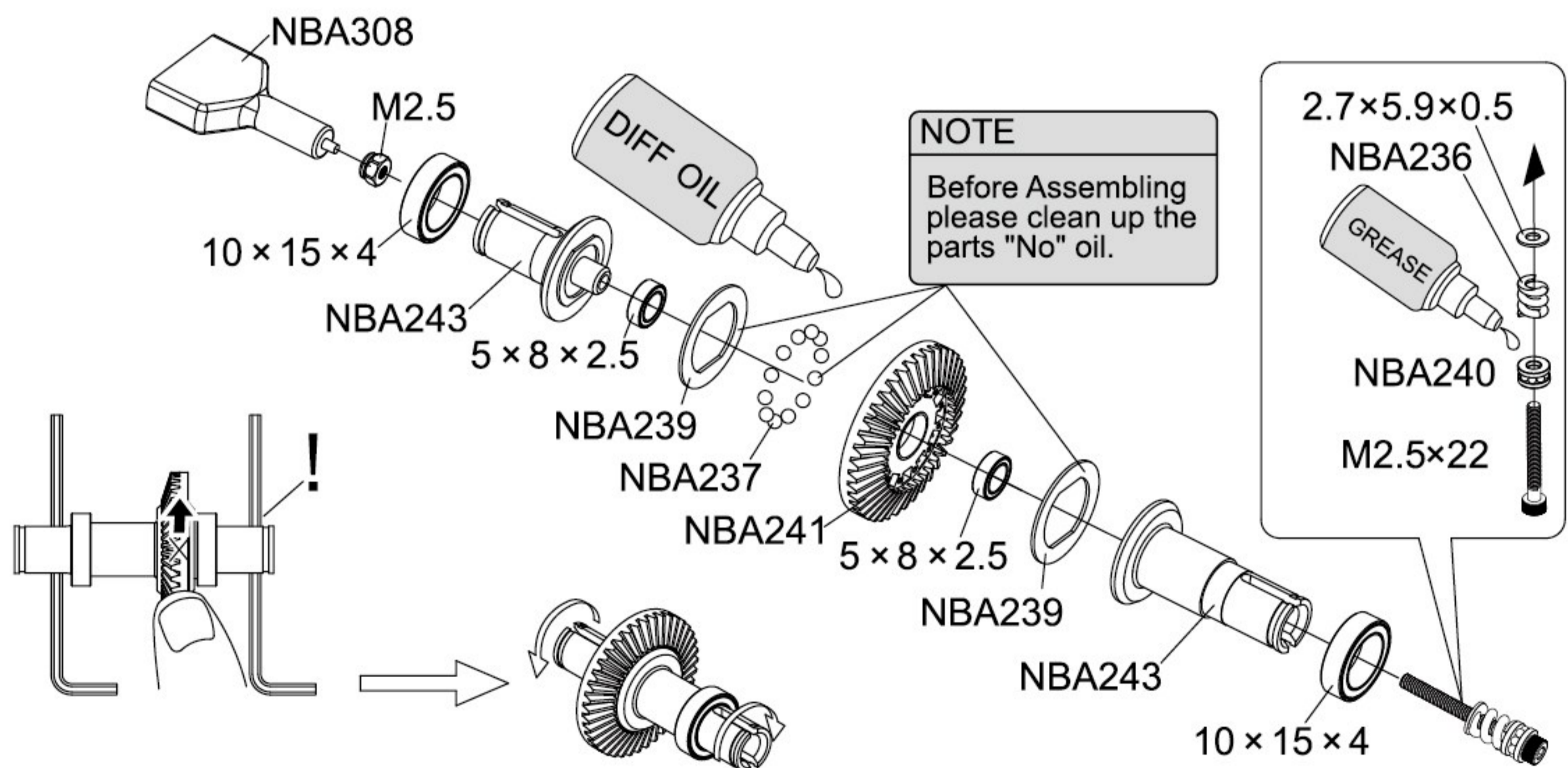

NOTE

The differential should be tightened until the gear cannot be rotated when both of the diff hubs are held. The differentials should turn smoothly after assembling.

OPTION

NBA244 Ball Diff cup joint (Metal)

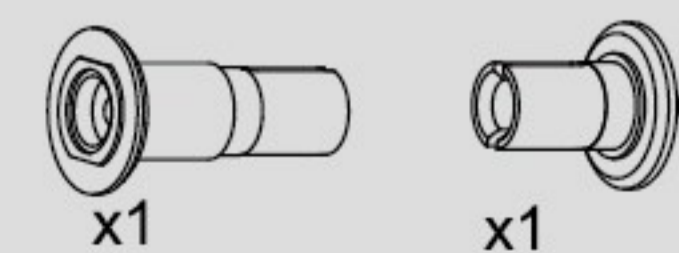



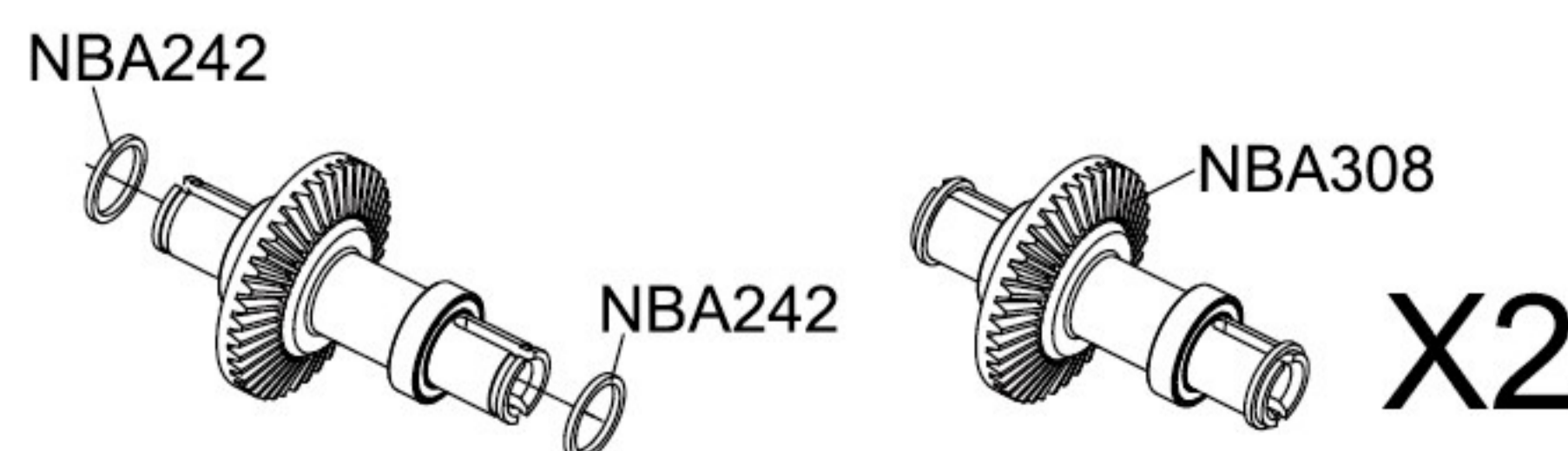



NBA309 Differential(Metal)

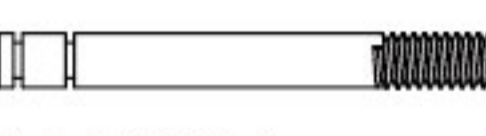

ALUMINUM SHOCK

3

-  X1
NBA222
-  X1
NBA220
-  X2
NBA221
2×5×0.5mm
-  X1
NBA221
-  X1
NBA219
-  X1
NBA223
-  X1
NBA223
-  X1
NBA223

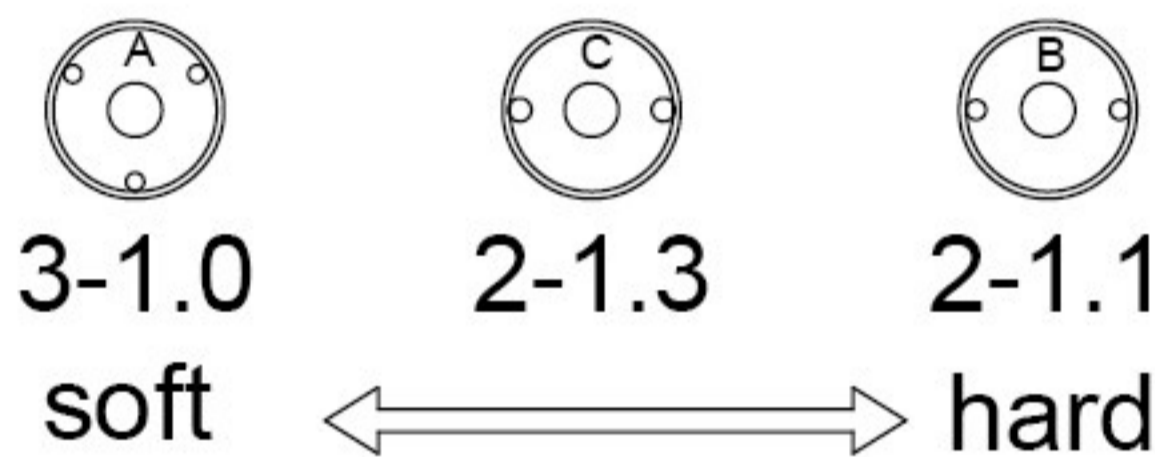
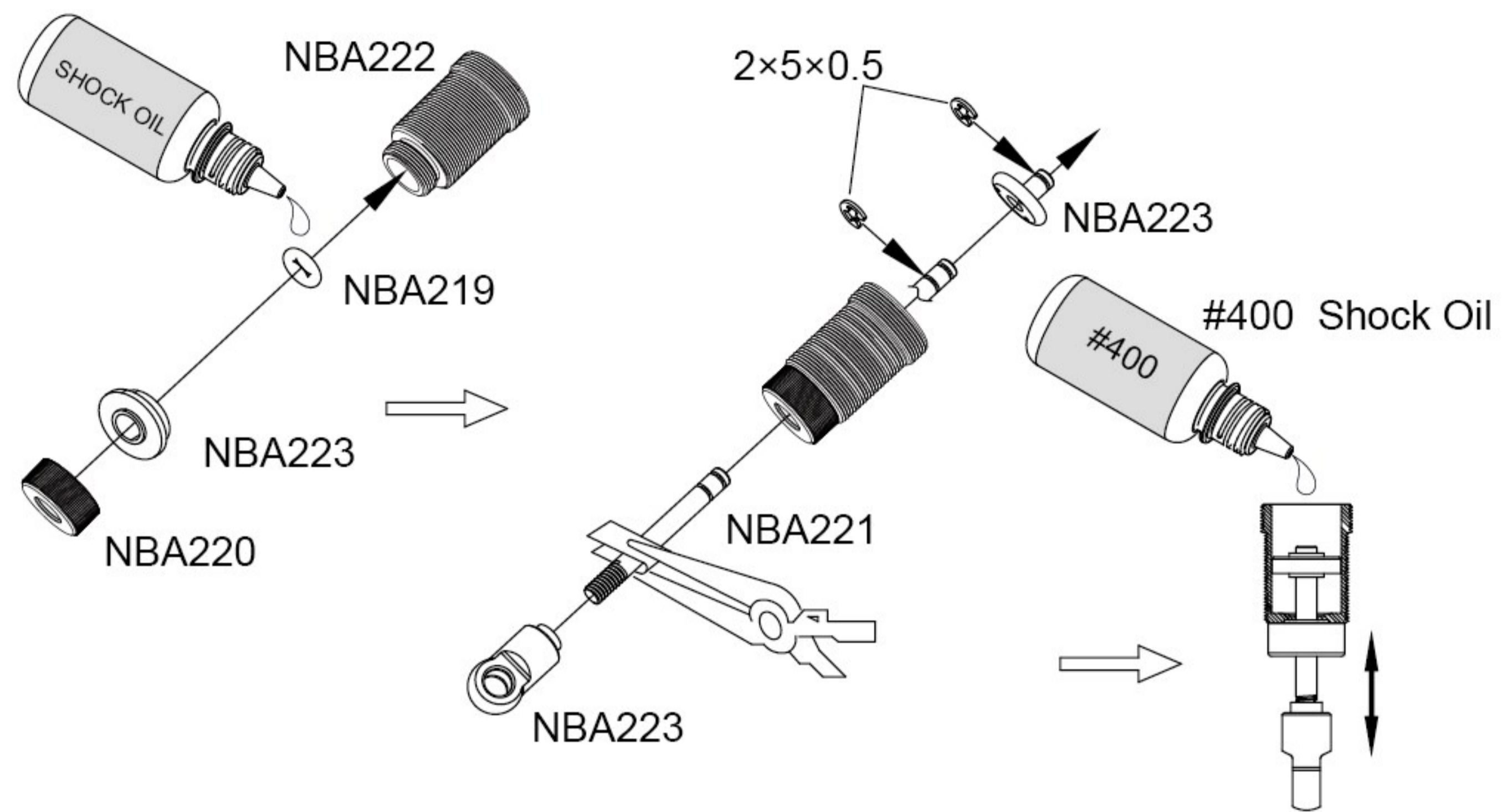

OPTION

-  X4
NBA362 Shock Spacer
-  X4
NBA363 Shock Pistons-3H1.2
-  X4
NBA364 Shock Pistons-4H1.1

4

-  X1
NBA220
-  X1
NBA220
-  X1
NBA219
11×13×1mm
-  X1
NBA223
-  X1
NBA223
-  X1
NBA219
-  X1
NBA219

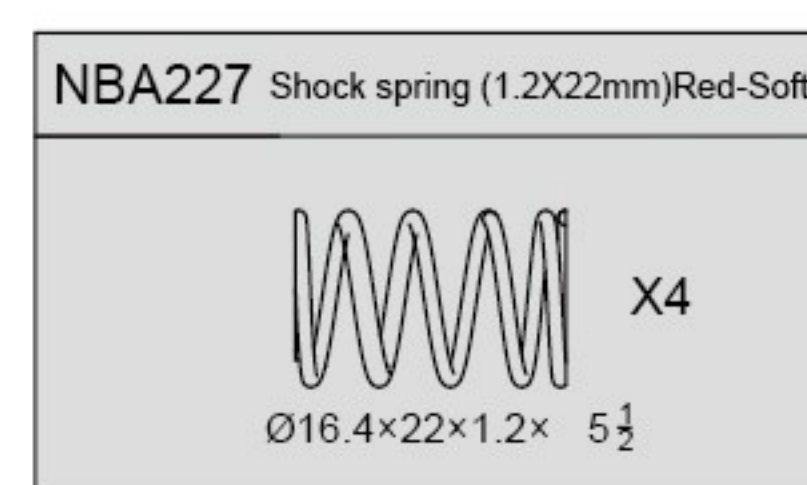
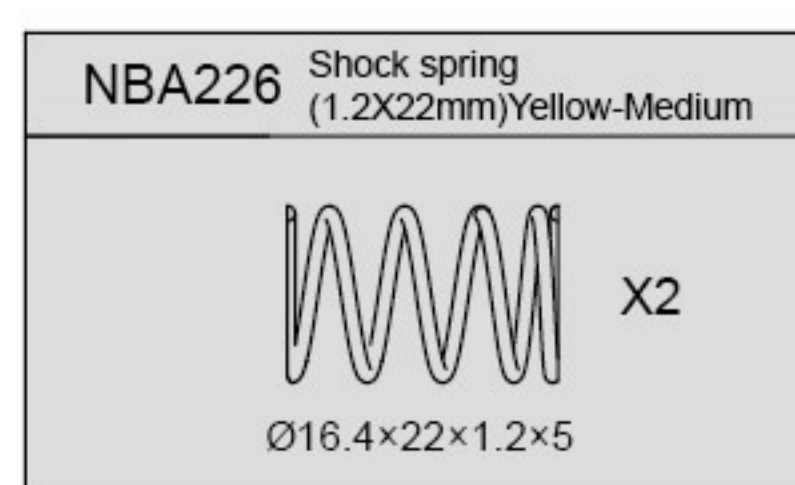
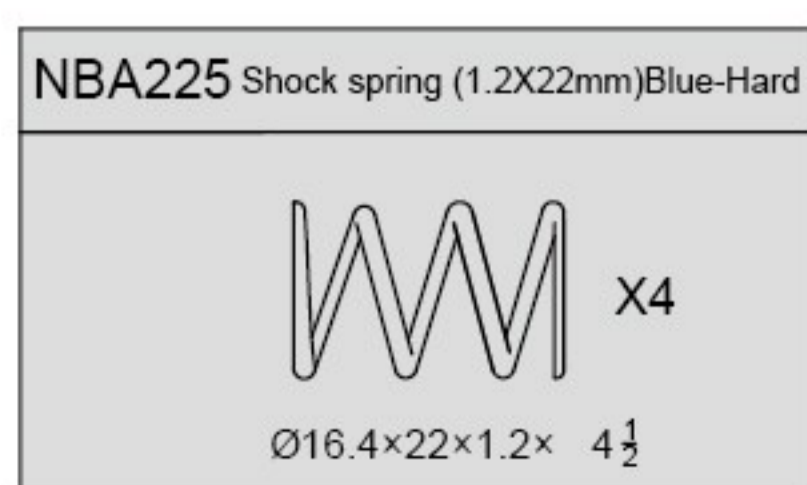
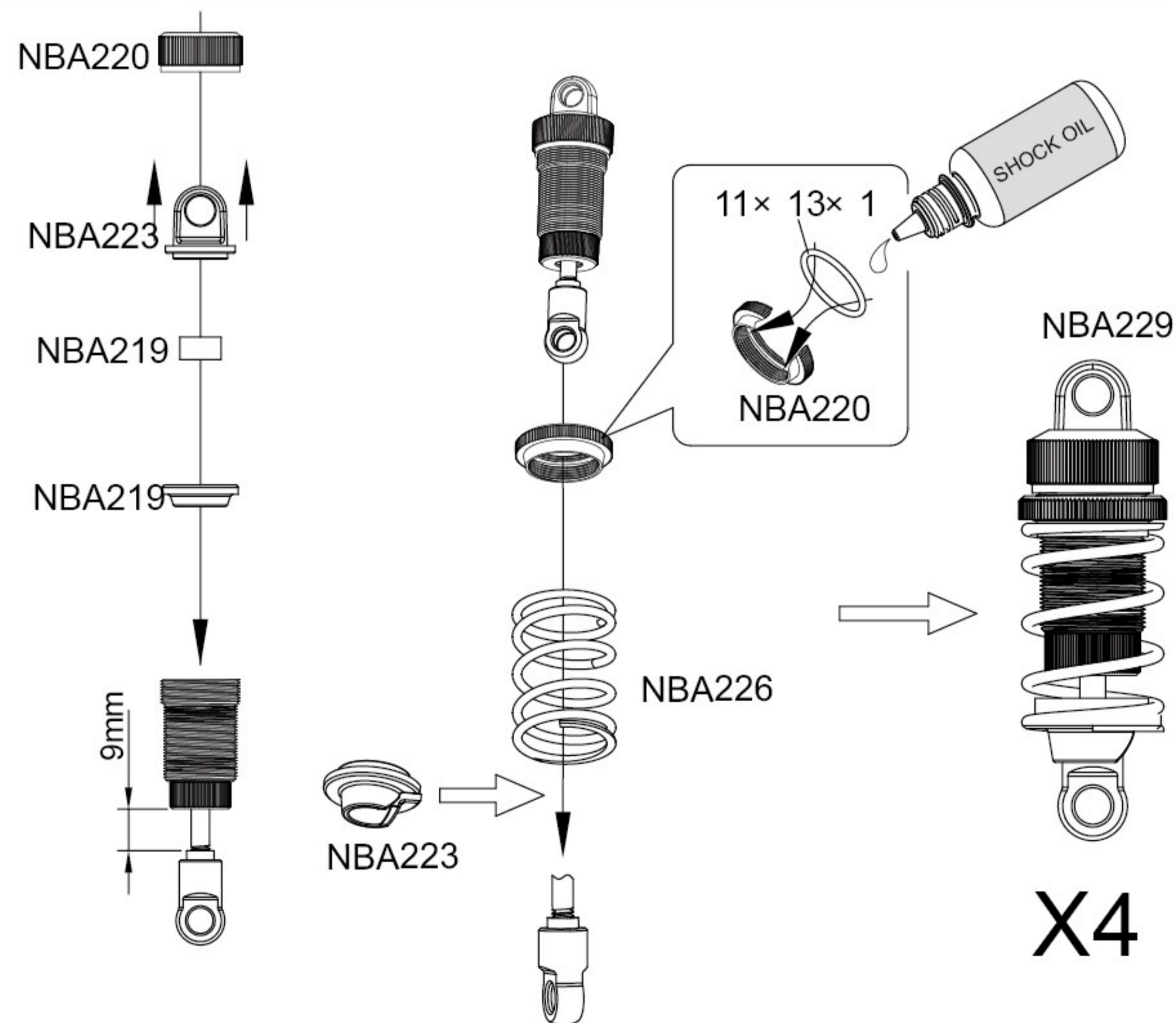

5

Plastic Oil Shocks

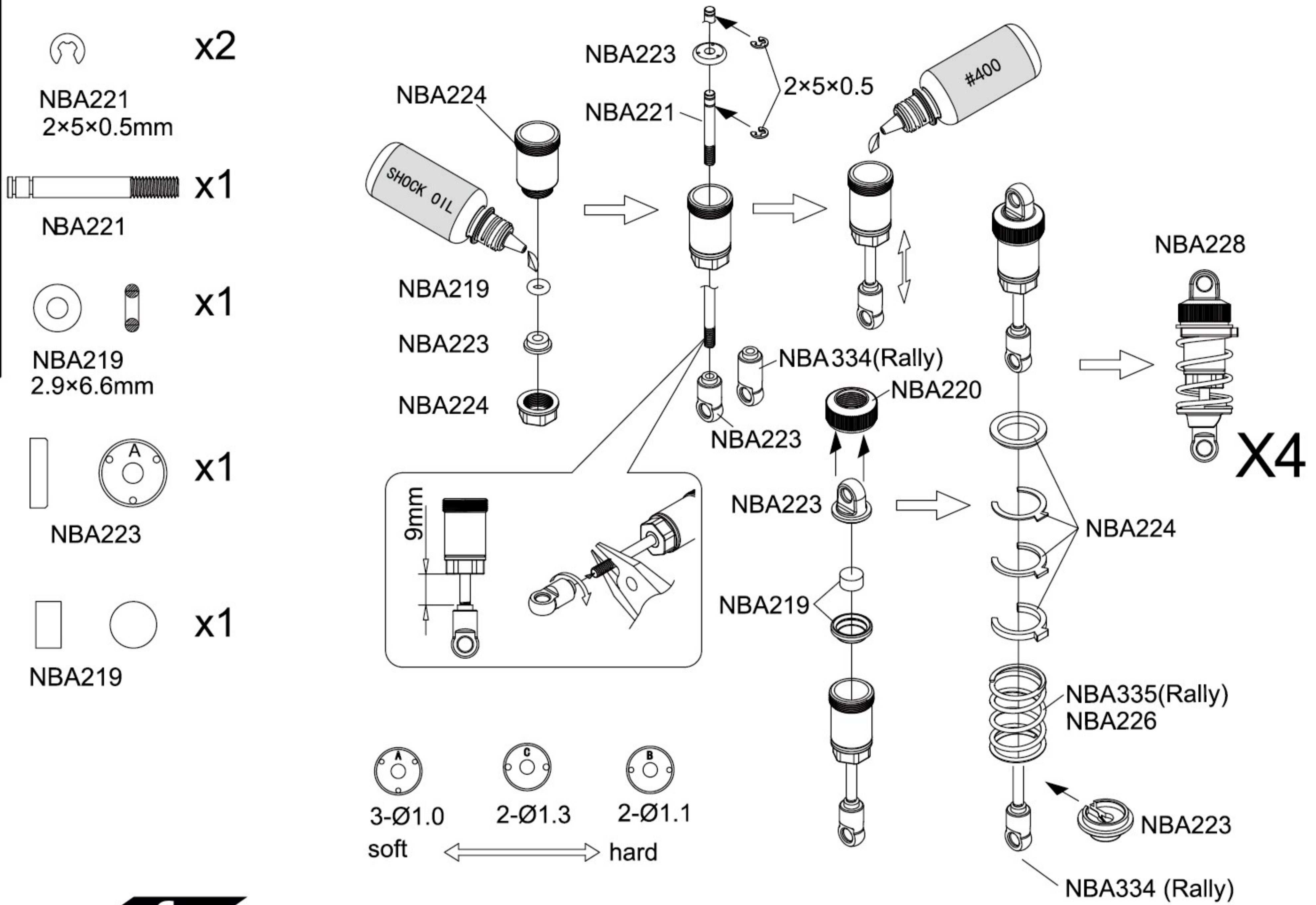

6

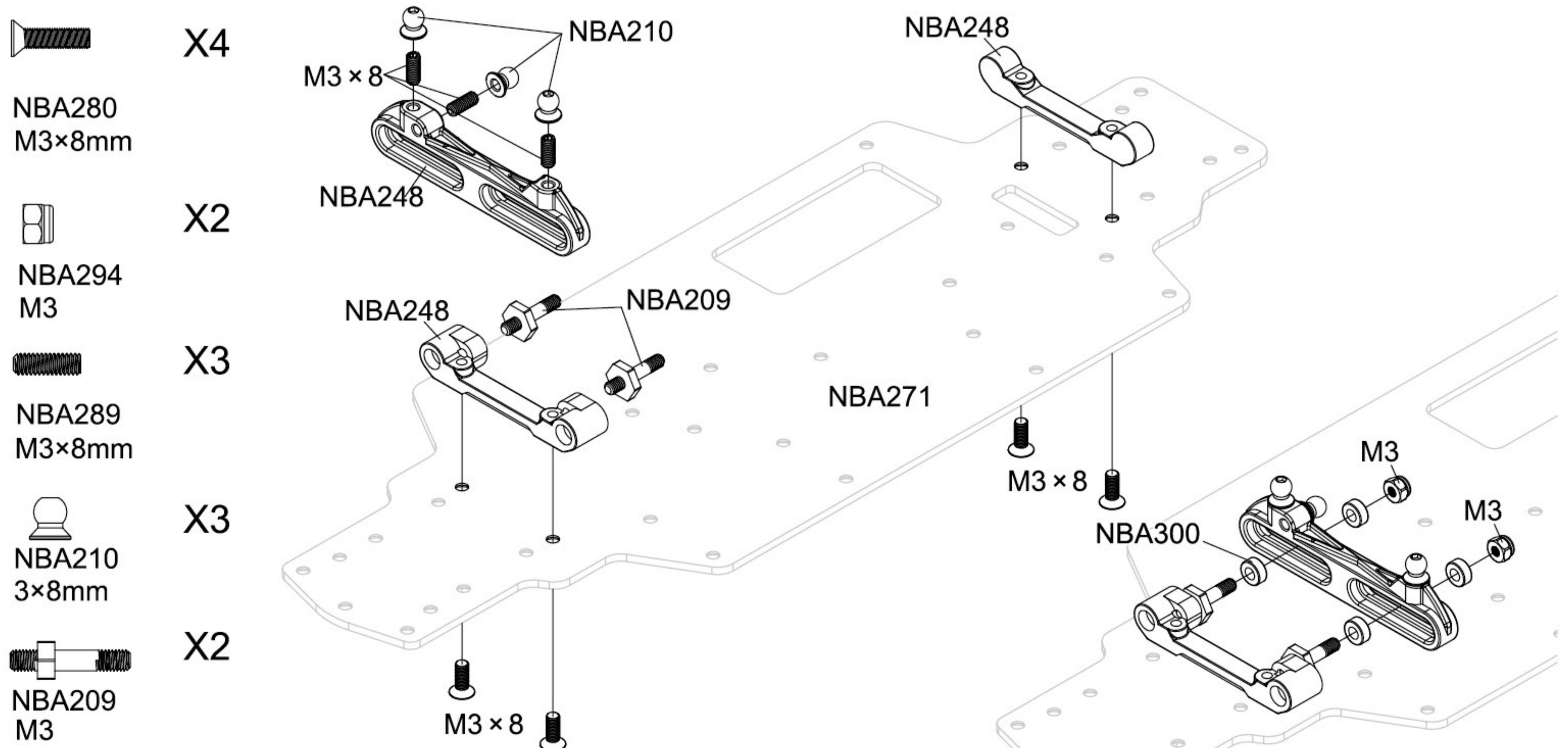

OPTION

NBA296 Bearing 3x6x2.5



x4

OPTION

NBA316 Pivot Block (ALUMINUM)



x1

OPTION

NBA317 Steering Mount (ALUMINUM)



x1

7

 X4

NBA280
M3×8mm

 X4

NBA290
M3×10mm

 X8

NBA211

 X4

NBA214

 X4

NBA289
M3×8mm

 X4

NBA210
3×8mm

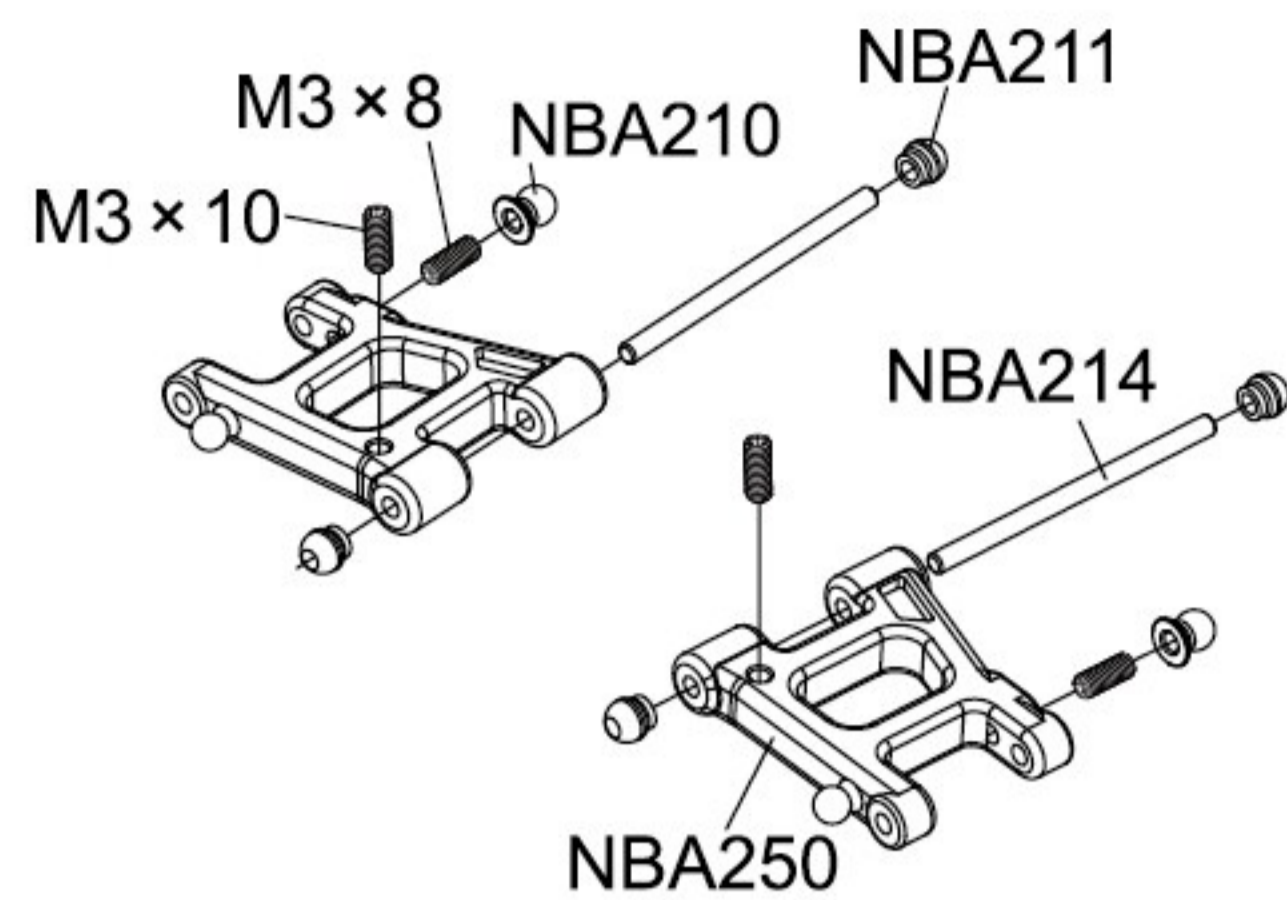
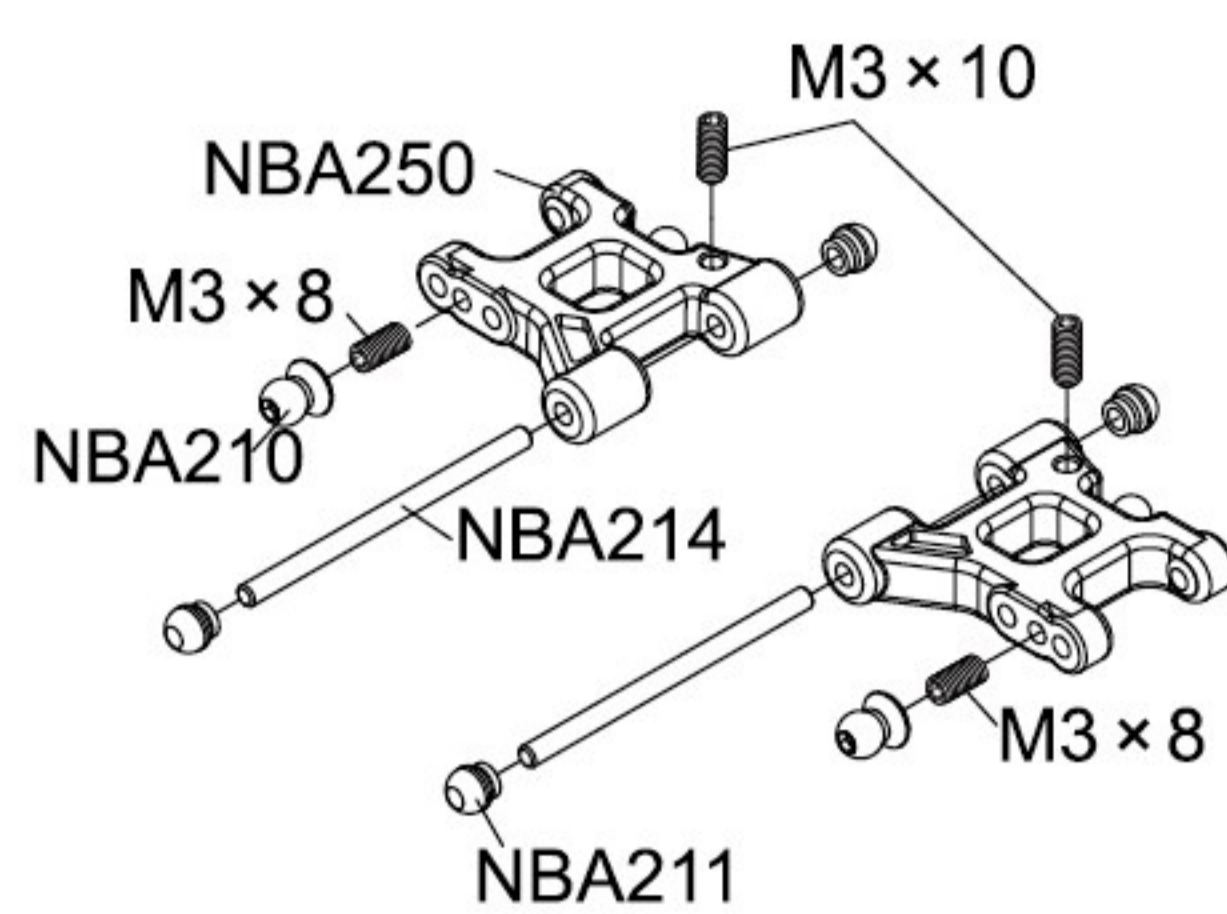

NOTE:
Do not overtighten the steering bolt, and keep steering smoothly.

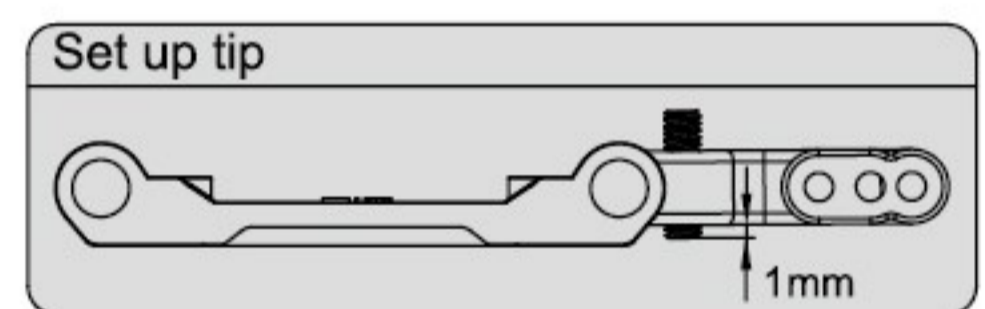
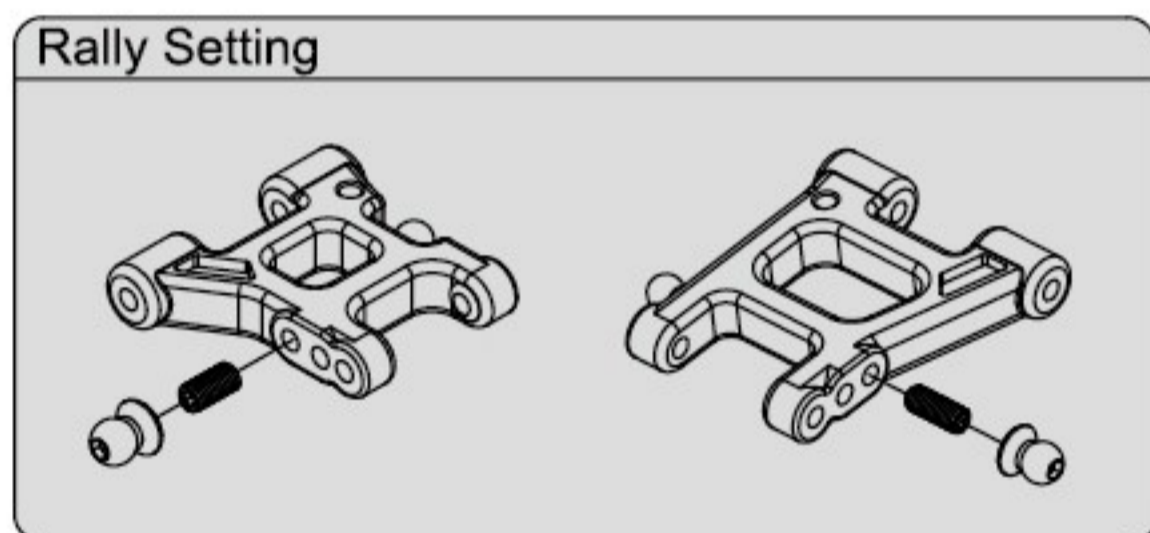
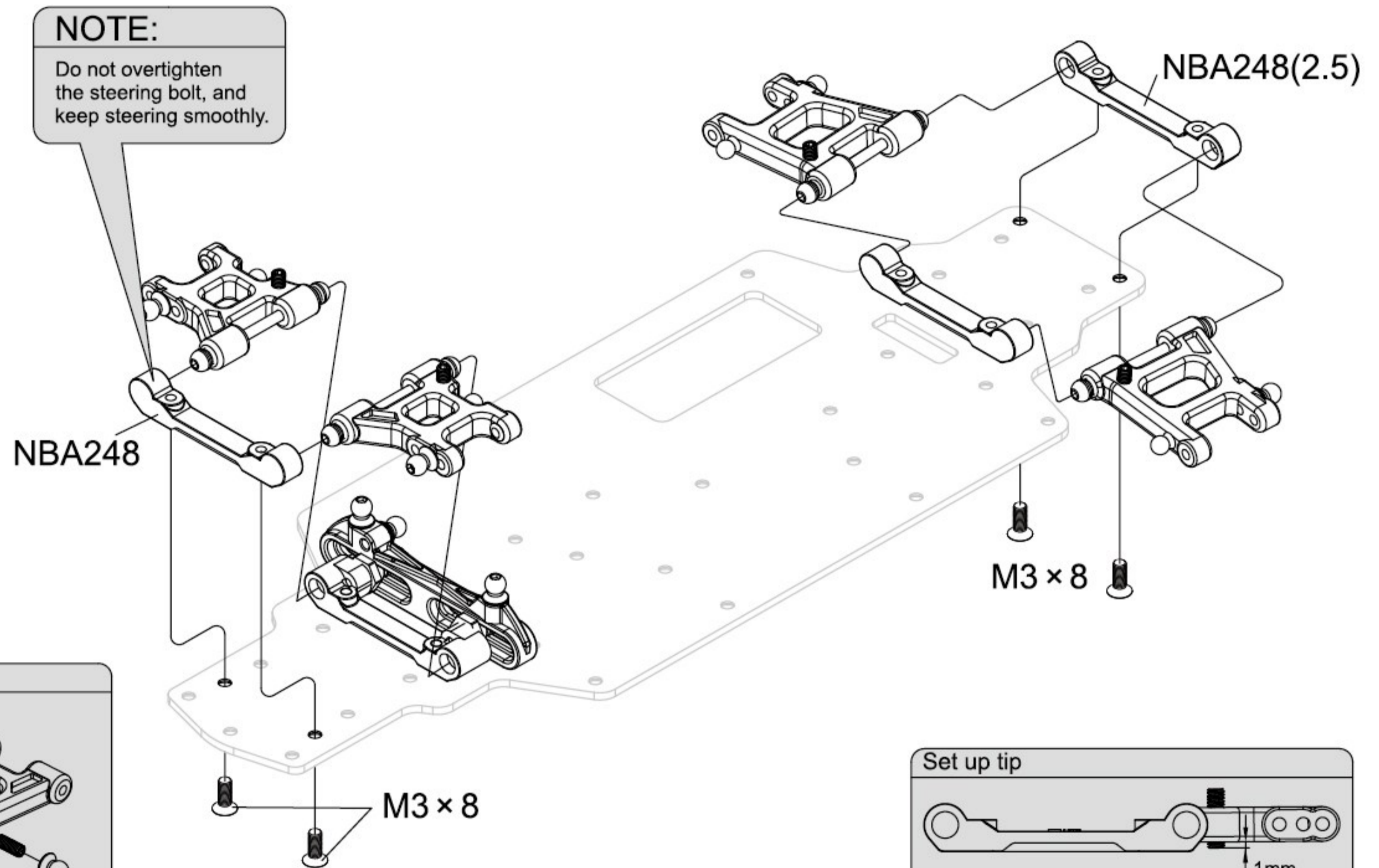

8

 X8

NBA280
M3×8mm

OPTION

NBA314 Pivot Block (ALUMINUM) 0°



NBA315 Pivot Block (ALUMINUM) 2.5°



NBA338 Pivot Block (ALUMINUM) 2.0°

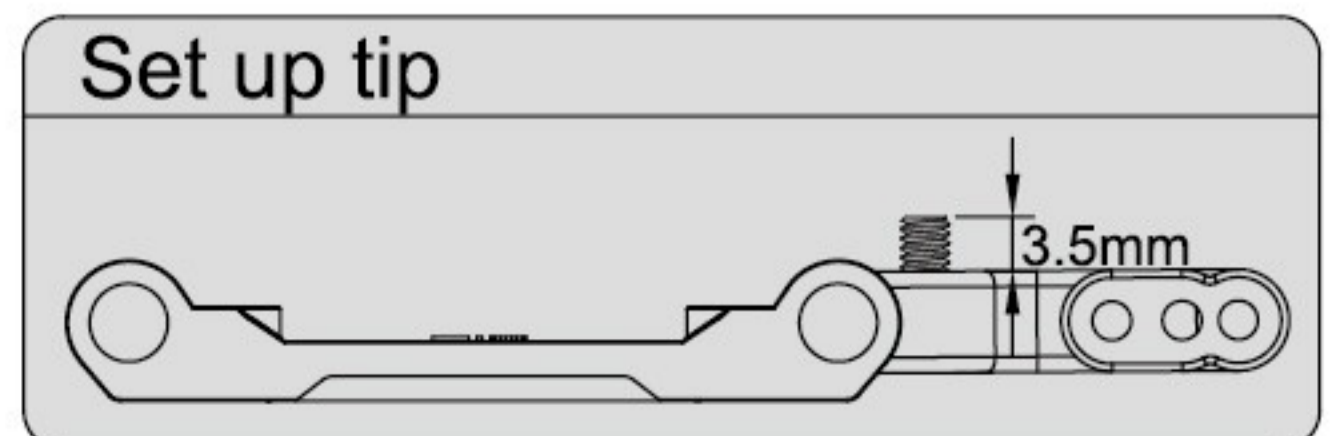
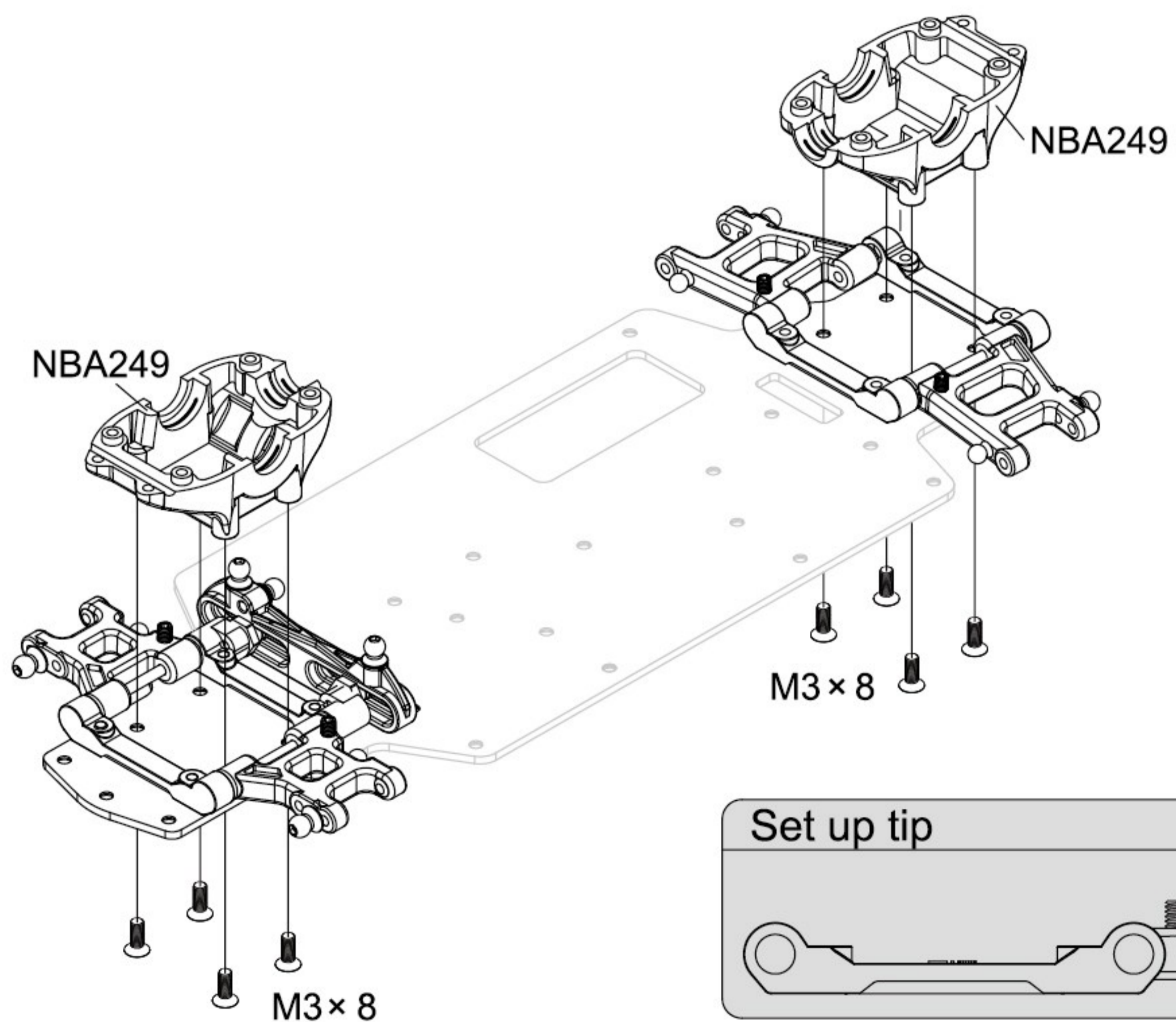
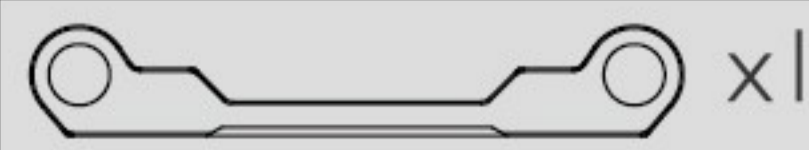

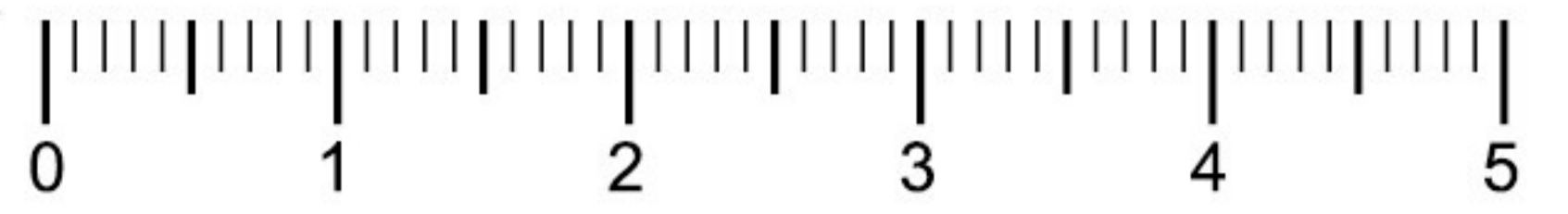

9

 X1
NBA284
M3×8mm

 X1
NBA210
3×8mm

 X1
NBA281
M3×6mm

 X1
NBA254
(Black)

 X2
NBA254
(Silver)

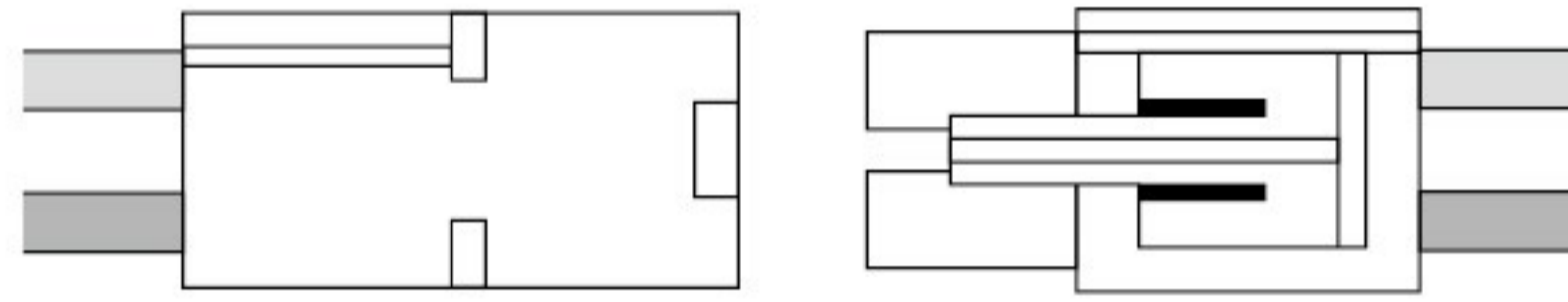
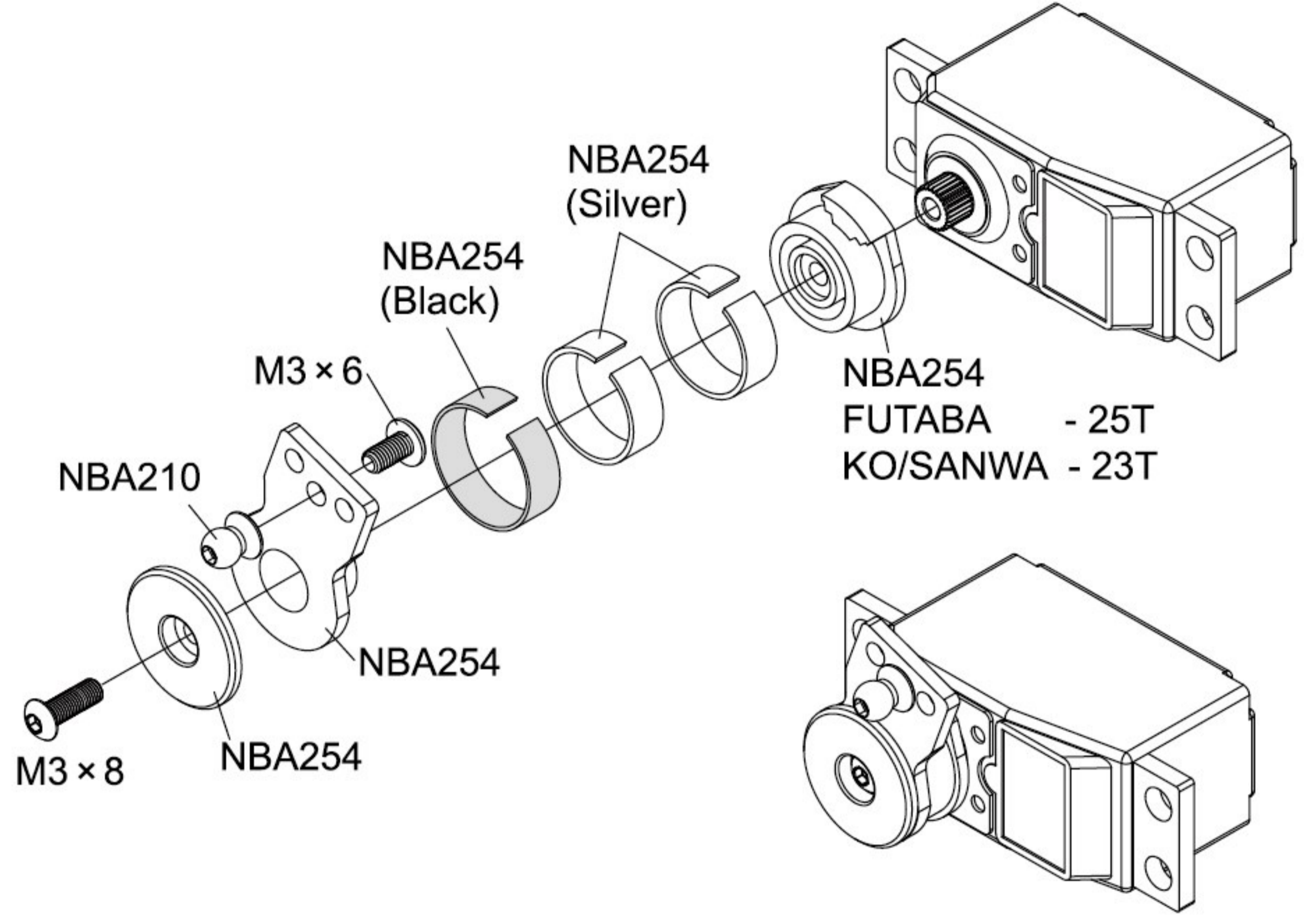

- 1: Switch on transmitter
- 2: Connecting battery and turn on ESC switch

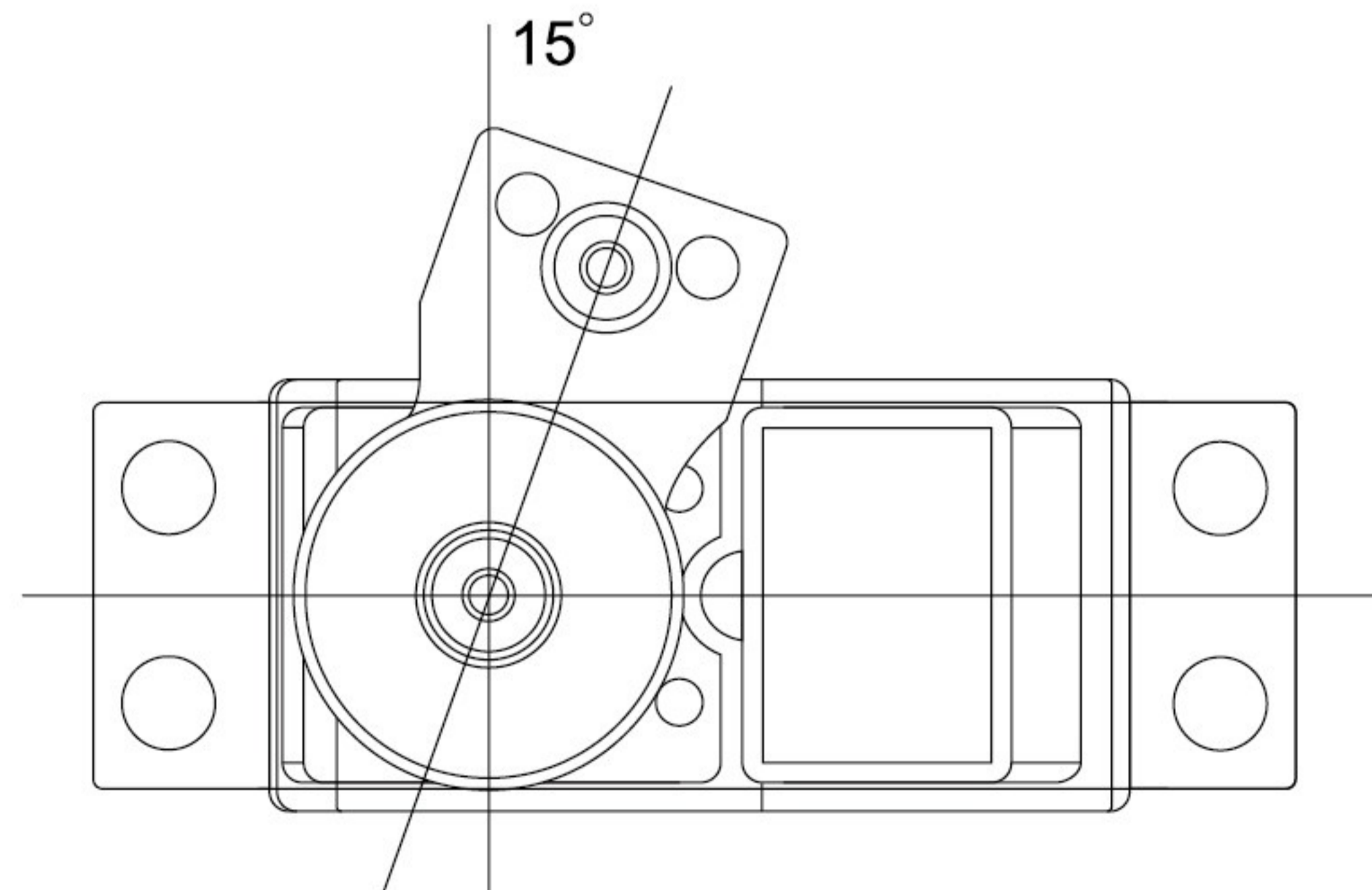

Servo in neutral position and attaching servo saver(15 Degree)

10

 X8

NBA281
M3×6mm

 X4

NBA302
3×8×0.5mm

 X2

NBA280
M3×8mm

 X2

NBA279
M3×6mm

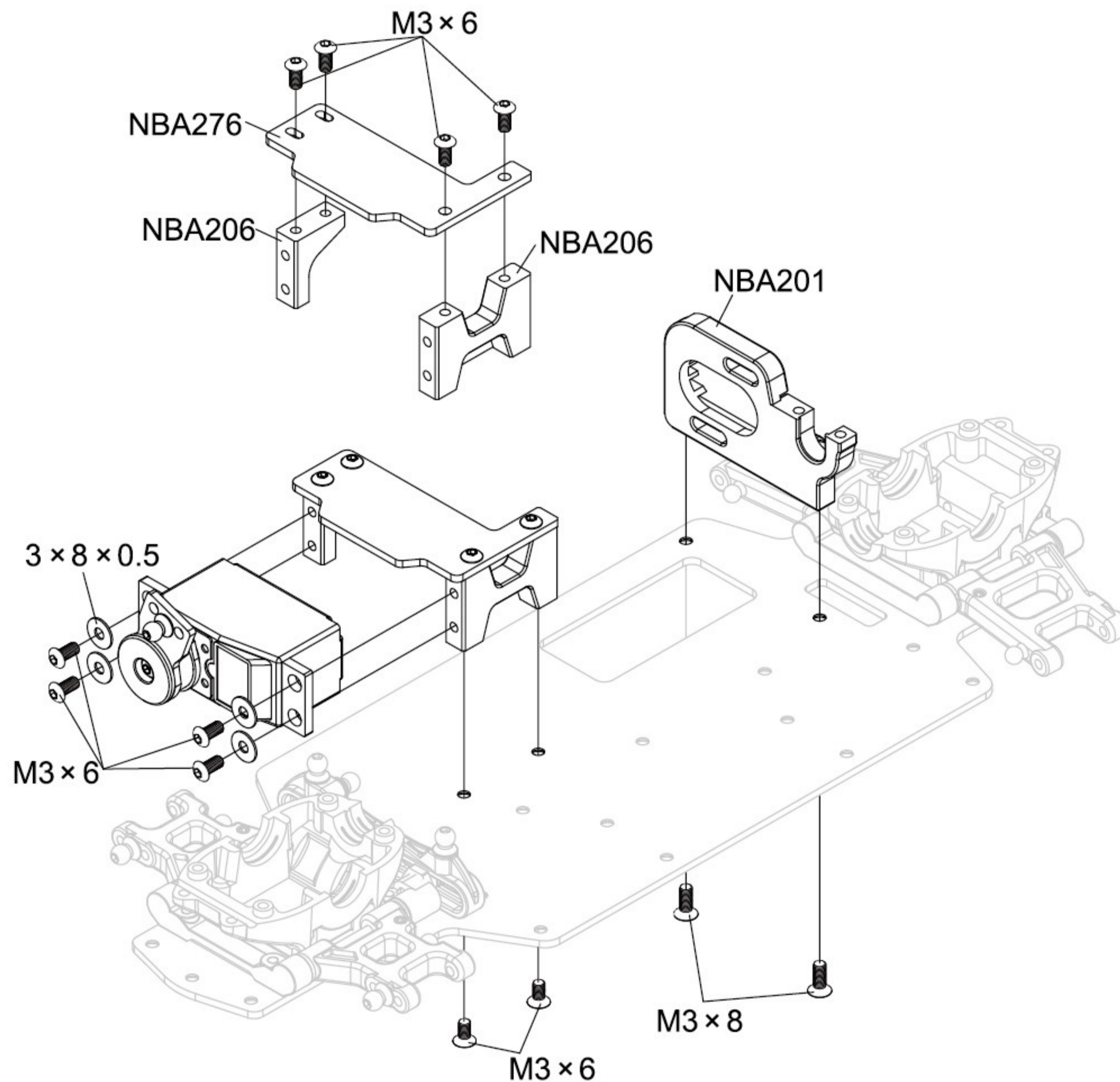

11

 X1

NBA279
M3×6mm

 X1

NBA280
M3×8mm

 X4

NBA298
5×10×4mm

 X2

NBA306
5.8×9.6×1.9mm

 X2

NBA255
2×7.6mm

GEAR DIFF

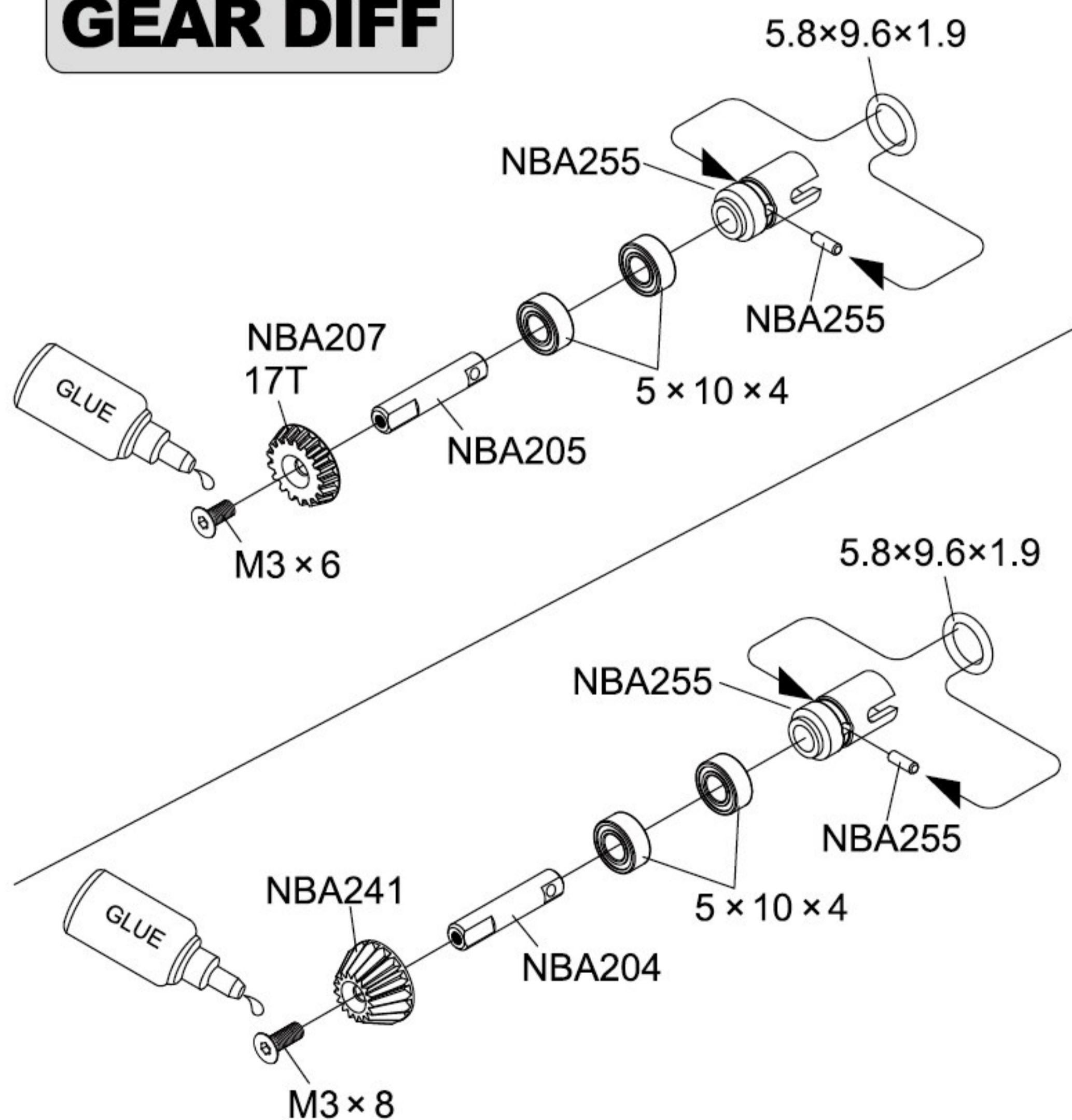

OPTION

NBA327 Metal Center Cup Joint
(For Gear Diff)

 x1  x1  x4  x4

OPTION

NBA326 Metal Center Cup Joint
(For Ball Diff)

 x2  x4  x4

BALL DIFF

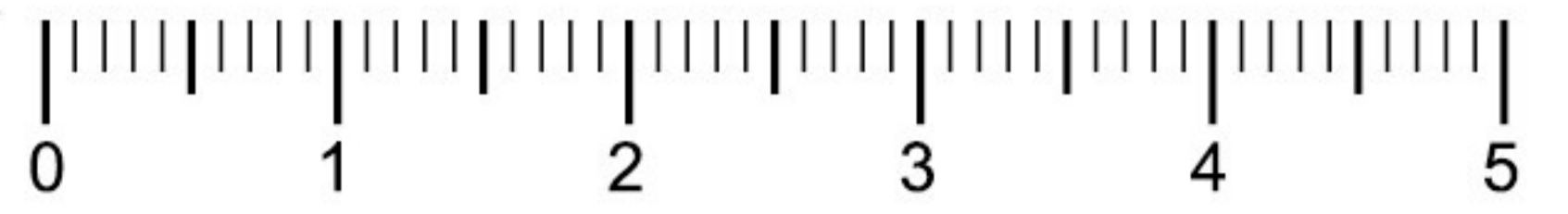

12

 X1

NBA279
M3×6mm

 X1

NBA280
M3×8mm

 X6

NBA298
5×10×4mm

 X2

NBA306
5.8×9.6×1.9mm

 X2

NBA255
2×7.6mm

 X8

NBA281
M3×6mm

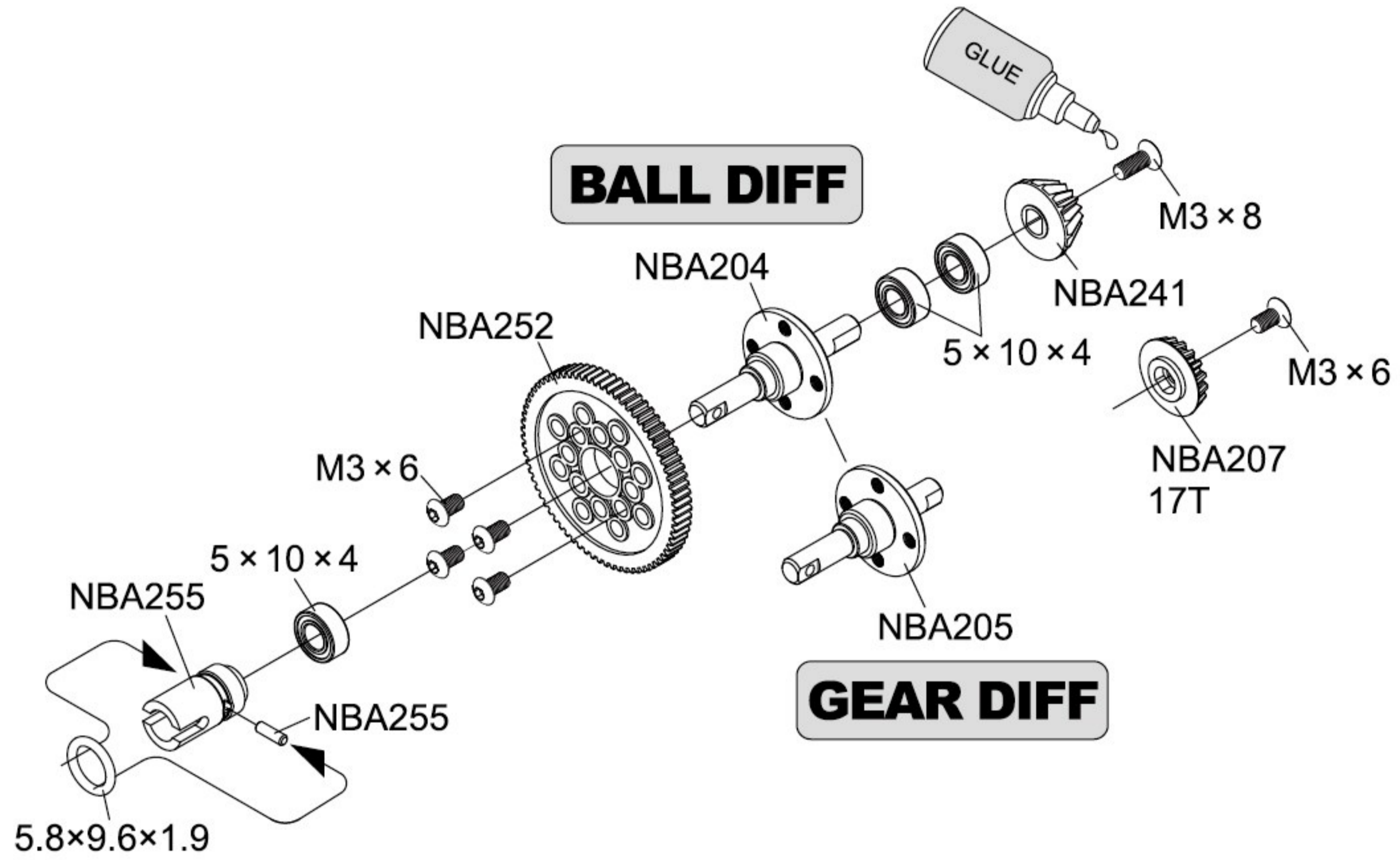

13

 X2

NBA283
M3×10mm

 X2

NBA282
M3×8mm

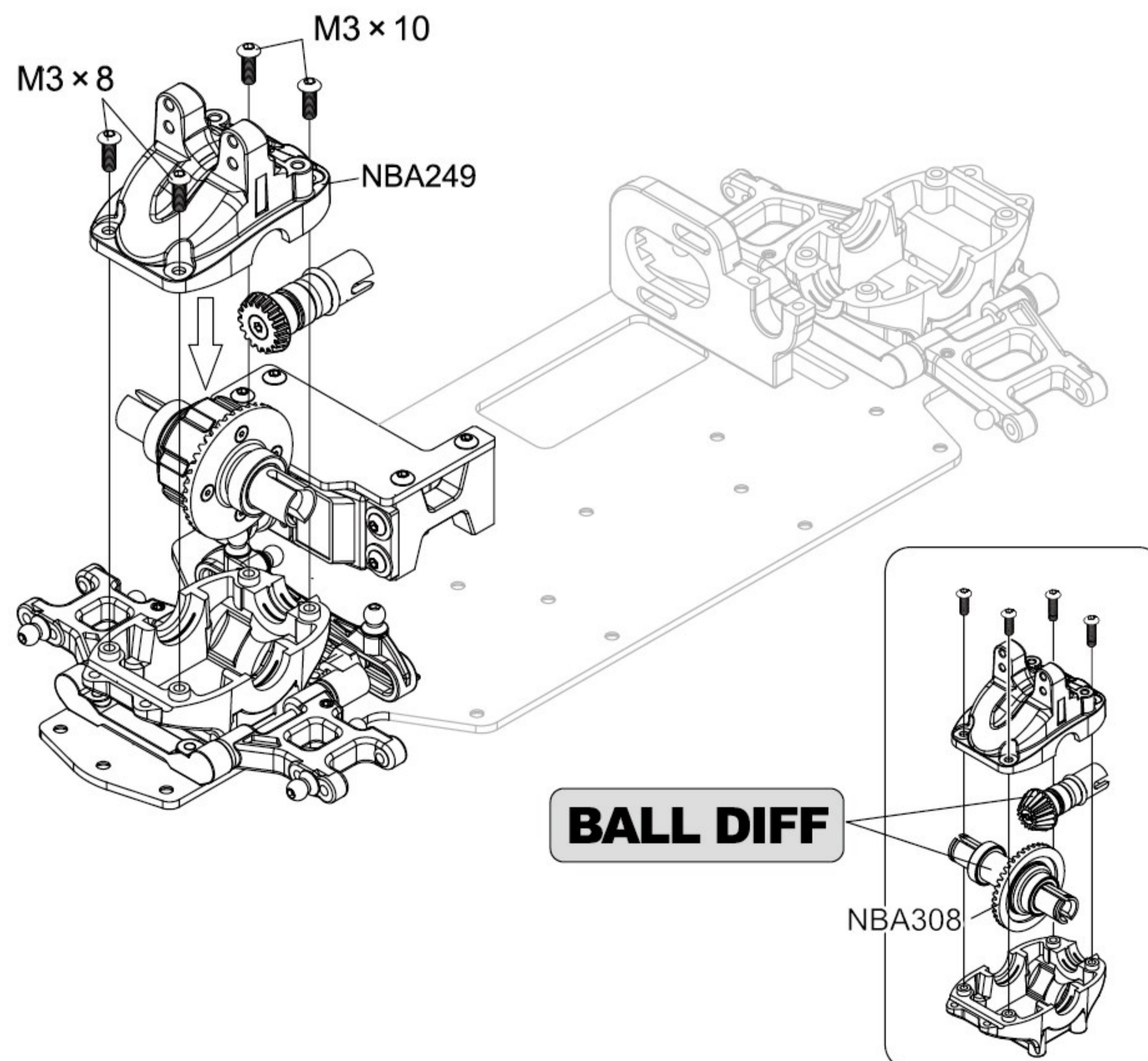

14

 X2

NBA283
M3×10mm

 X2

NBA282
M3×8mm

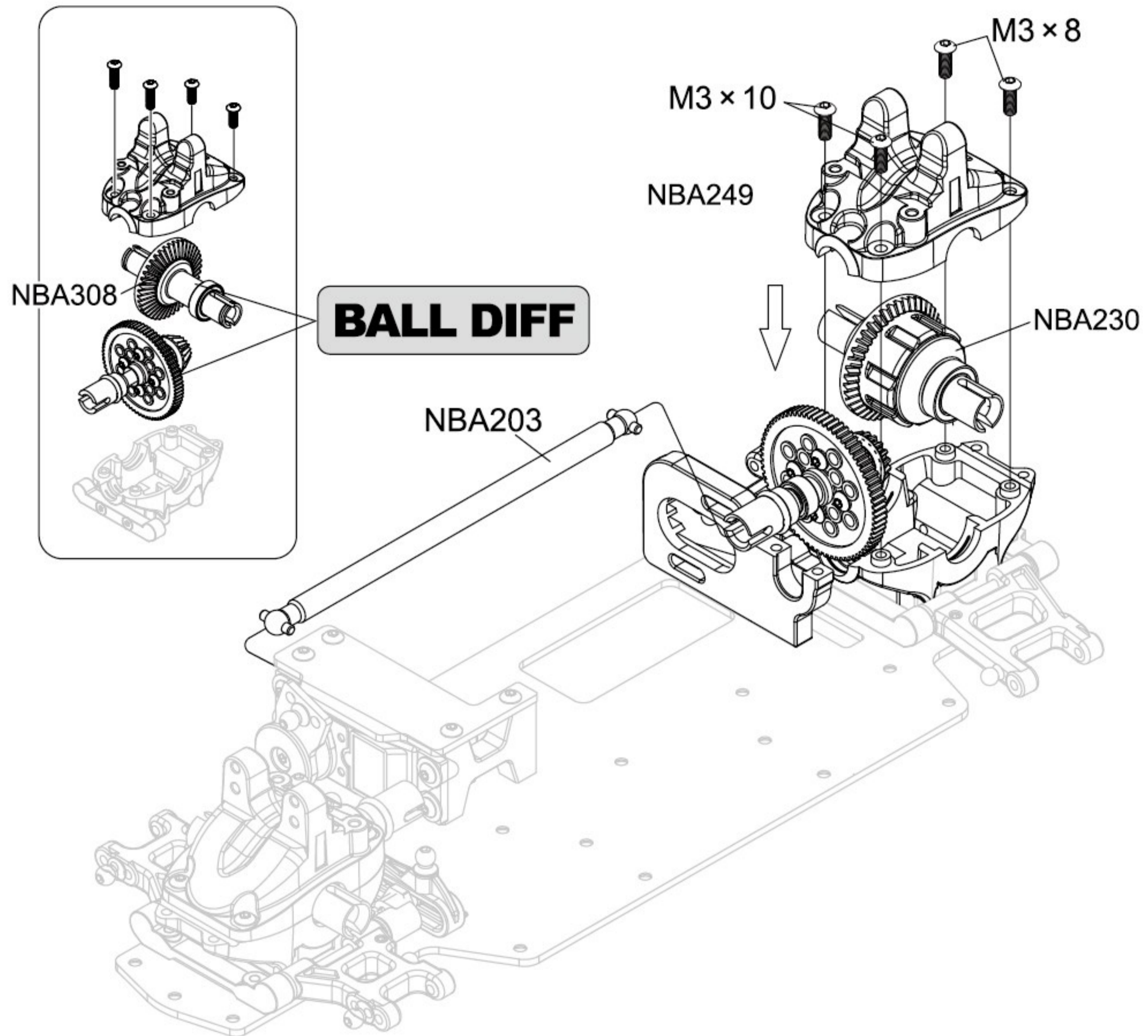

15

 X2

NBA304
2×10mm

 X4

NBA298
5×10×4mm

 X4

NBA283
M3×10mm

 X4

NBA212
3×7×4.2mm

 X2

NBA289
M3×8mm

 X4

NBA210
3×8mm

 X2

NBA282
M3×8mm

 X2

NBA287
M3×3mm

 X4

NBA301
3×6×0.5mm

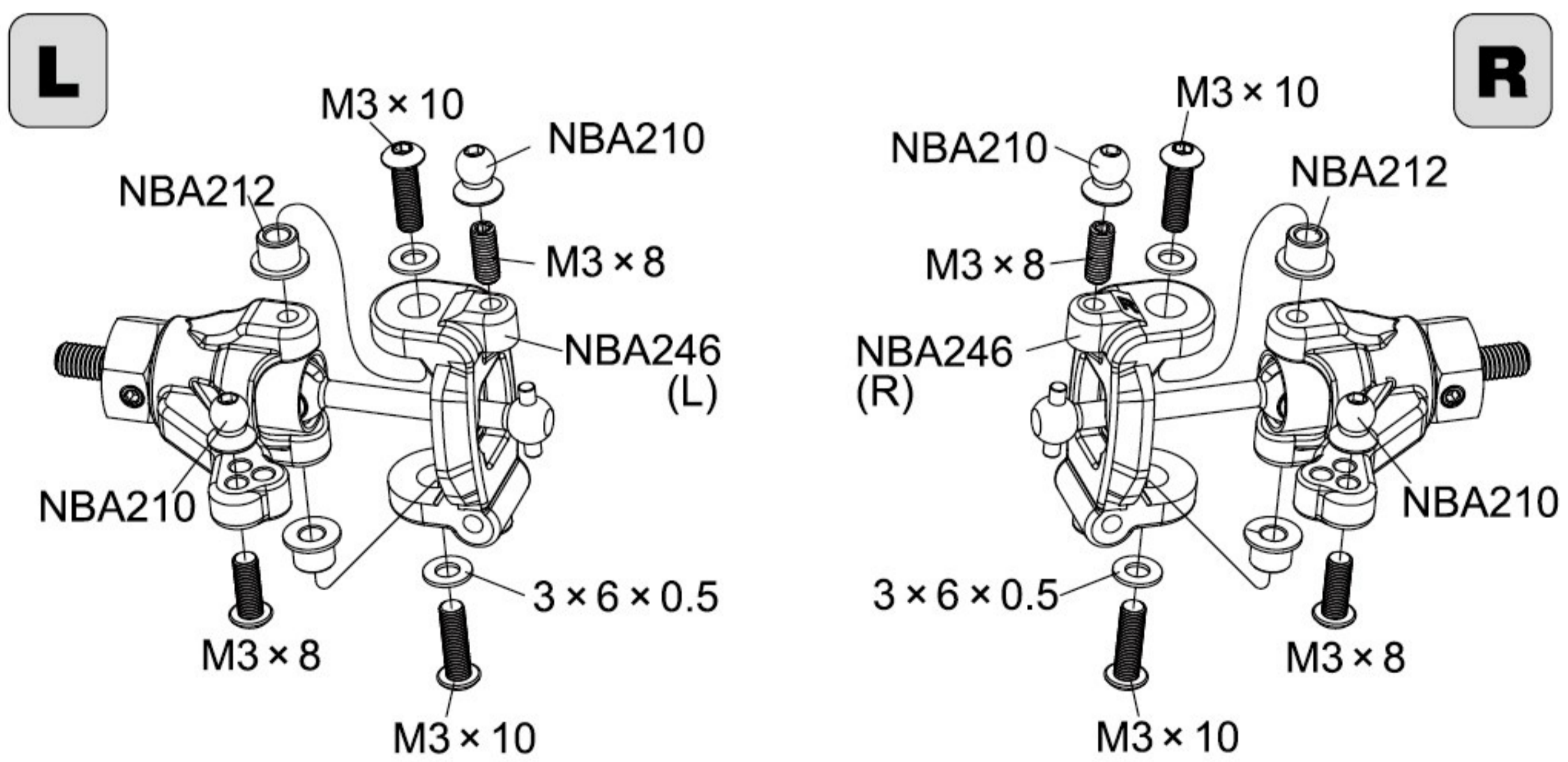
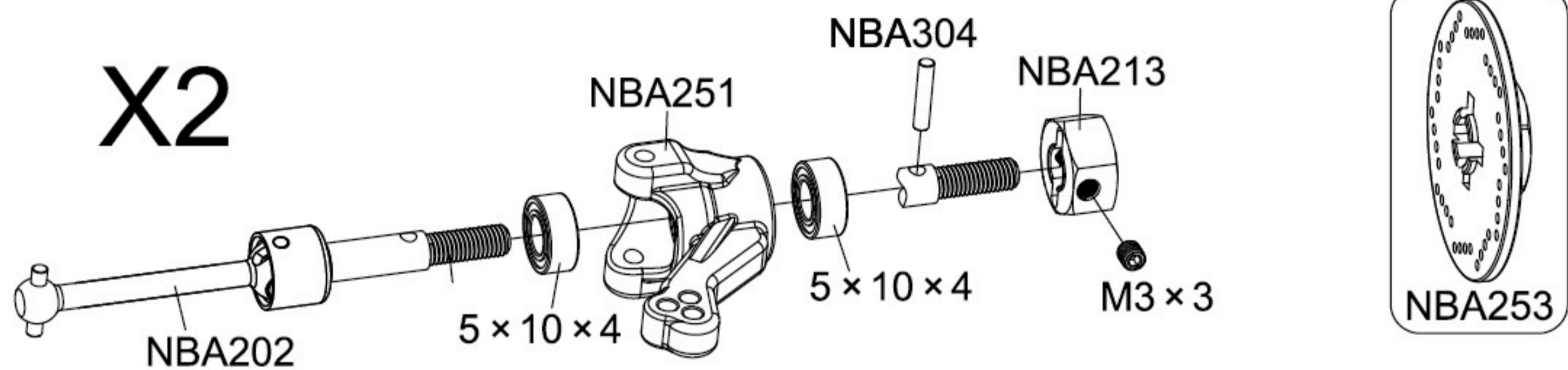

SET UP

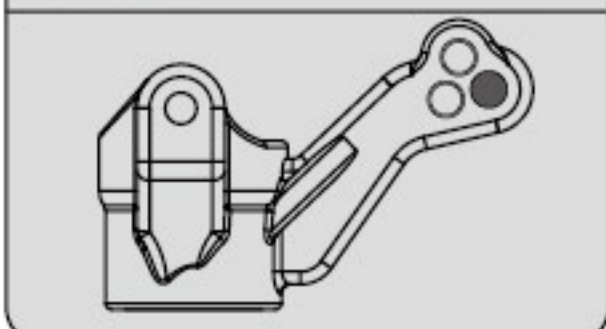

OPTION

NBA340 Aluminum C Hub(L/R)

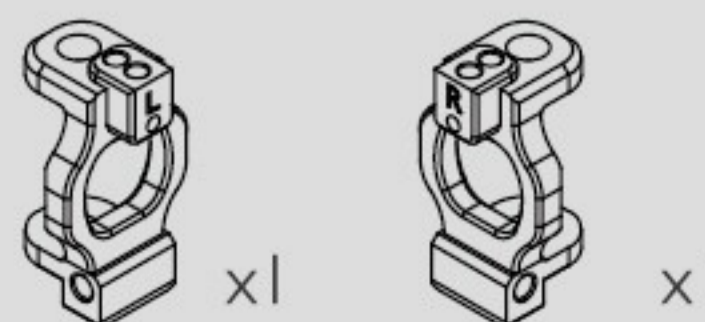

OPTION

NBA341 Aluminum Steering Blocks



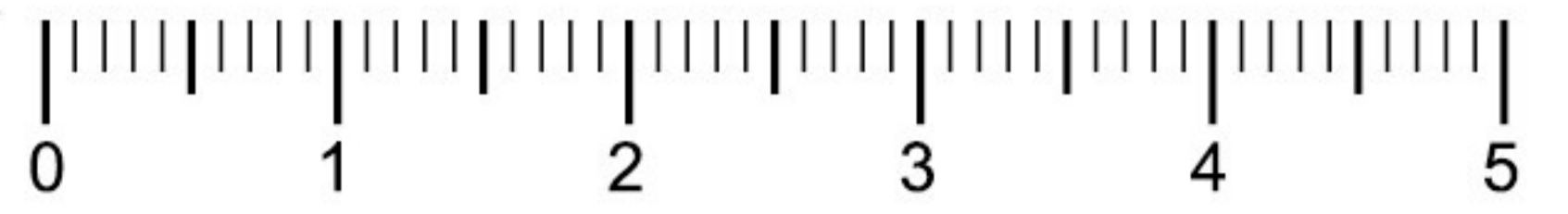

16

 X4

NBA298
5×10×4mm

 X2

NBA304
2×10mm

 X2

NBA289
M3×8mm

 X2

NBA210
3×8mm

 X2

NBA287
M3×3mm

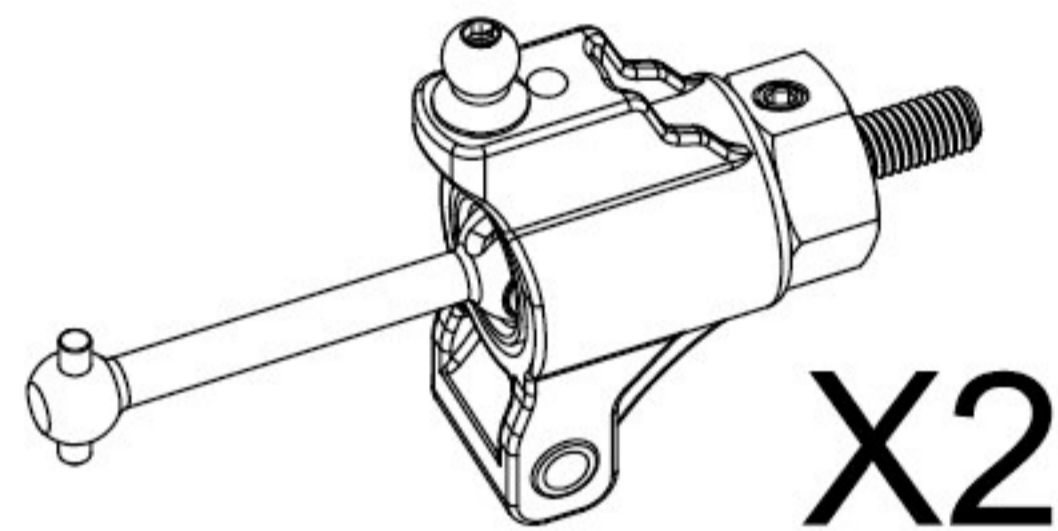
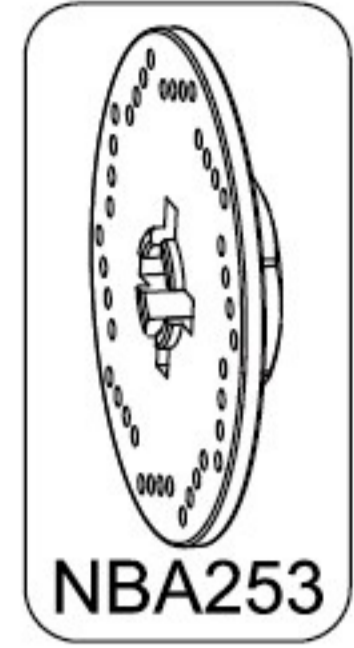
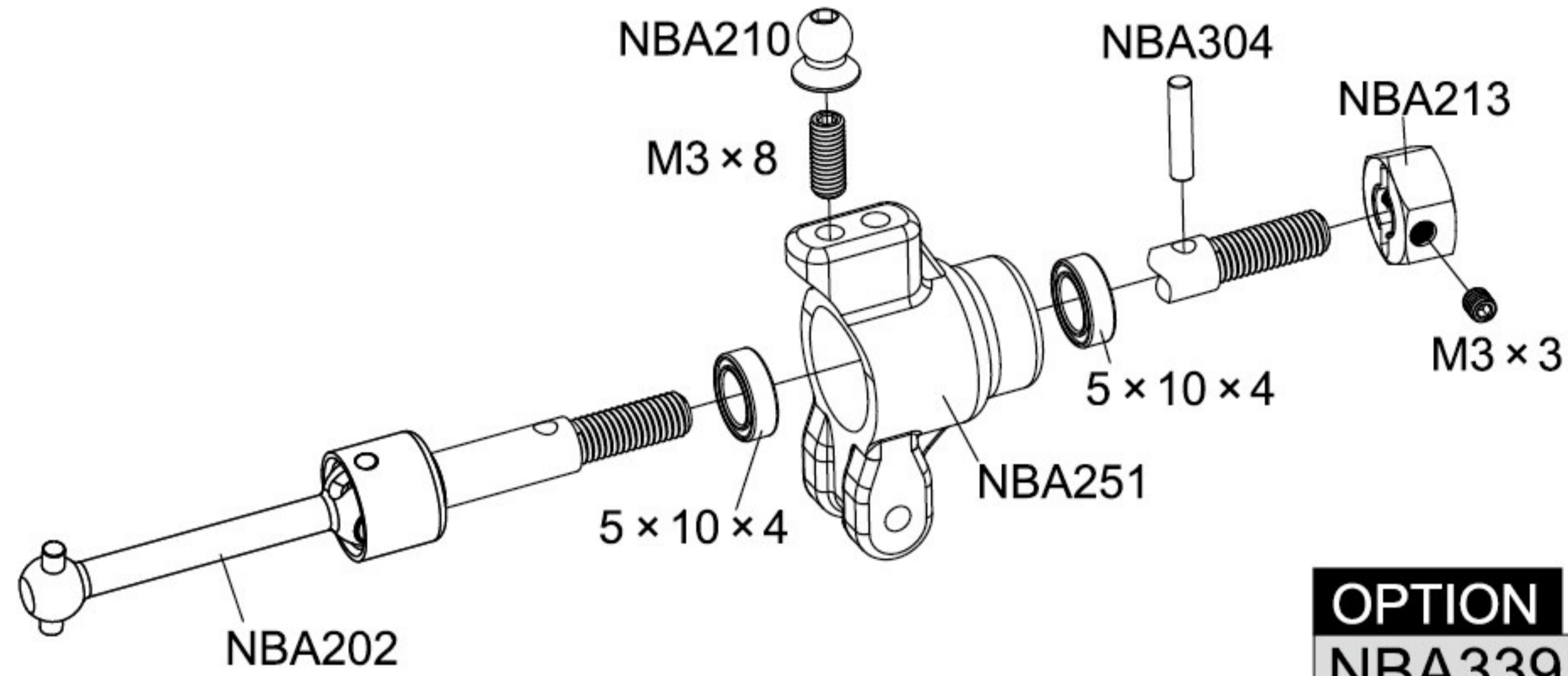

OPTION

NBA339 ALUMINUM REAR HUB

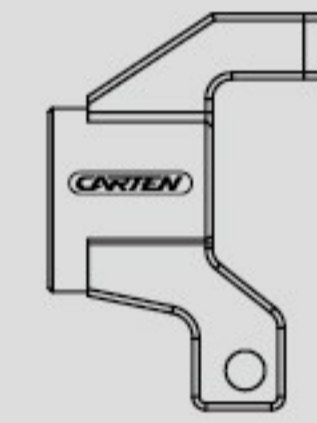

X2

NBA343 12mm Hex Hub (6mm)

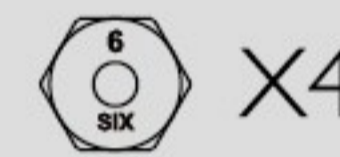

X4



X4



X4

NBA344 12mm Hex Hub (7mm)



X4



X4

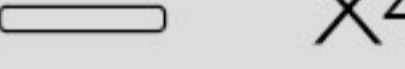

X4

17

 X2

NBA288
M3×4mm

 X2

NBA214
2.5 × 23mm

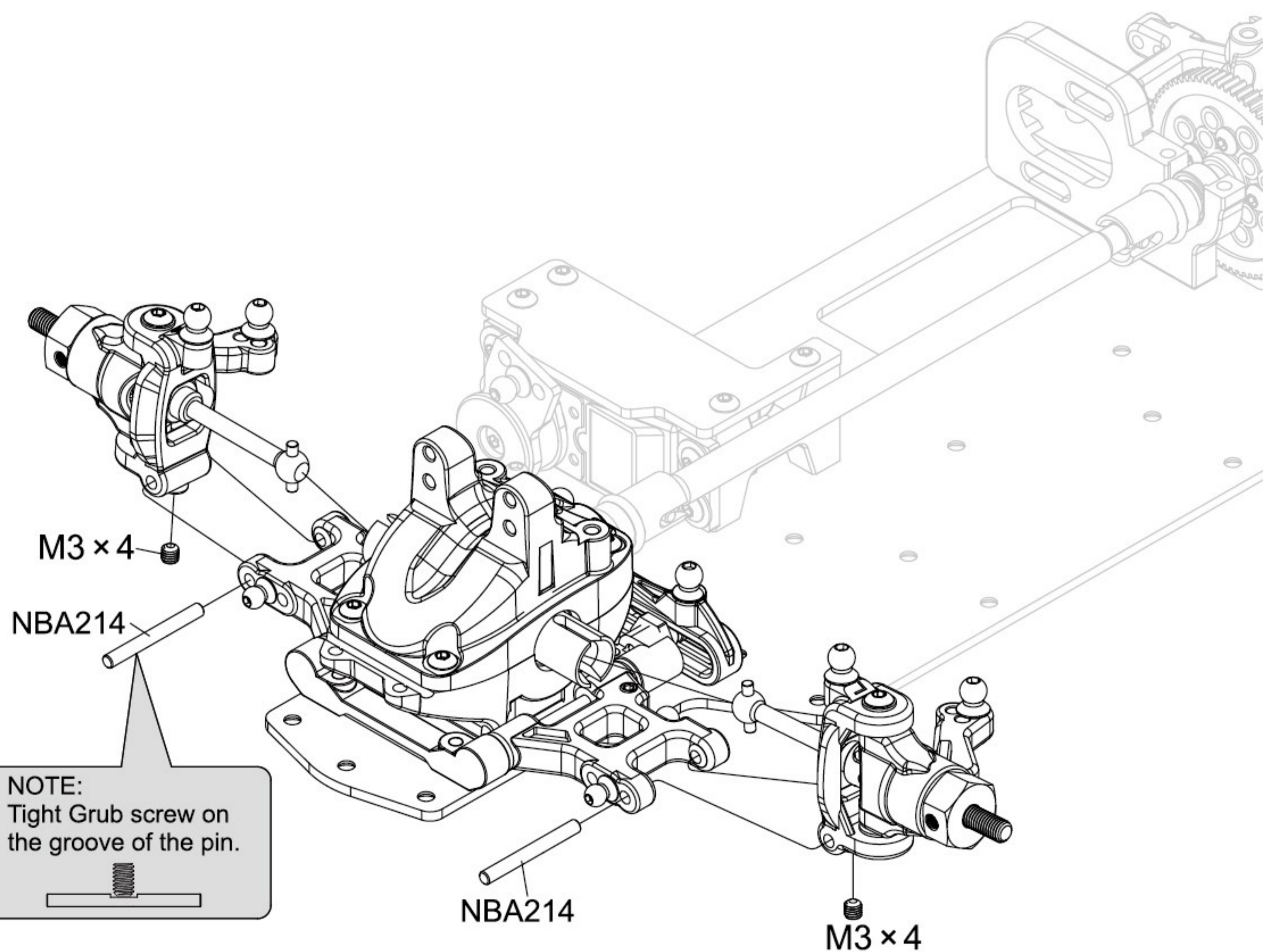

NOTE:
Tight Grub screw on
the groove of the pin.

18

 X2

NBA214
2.5×26mm

 X2

NBA288
M3×4mm

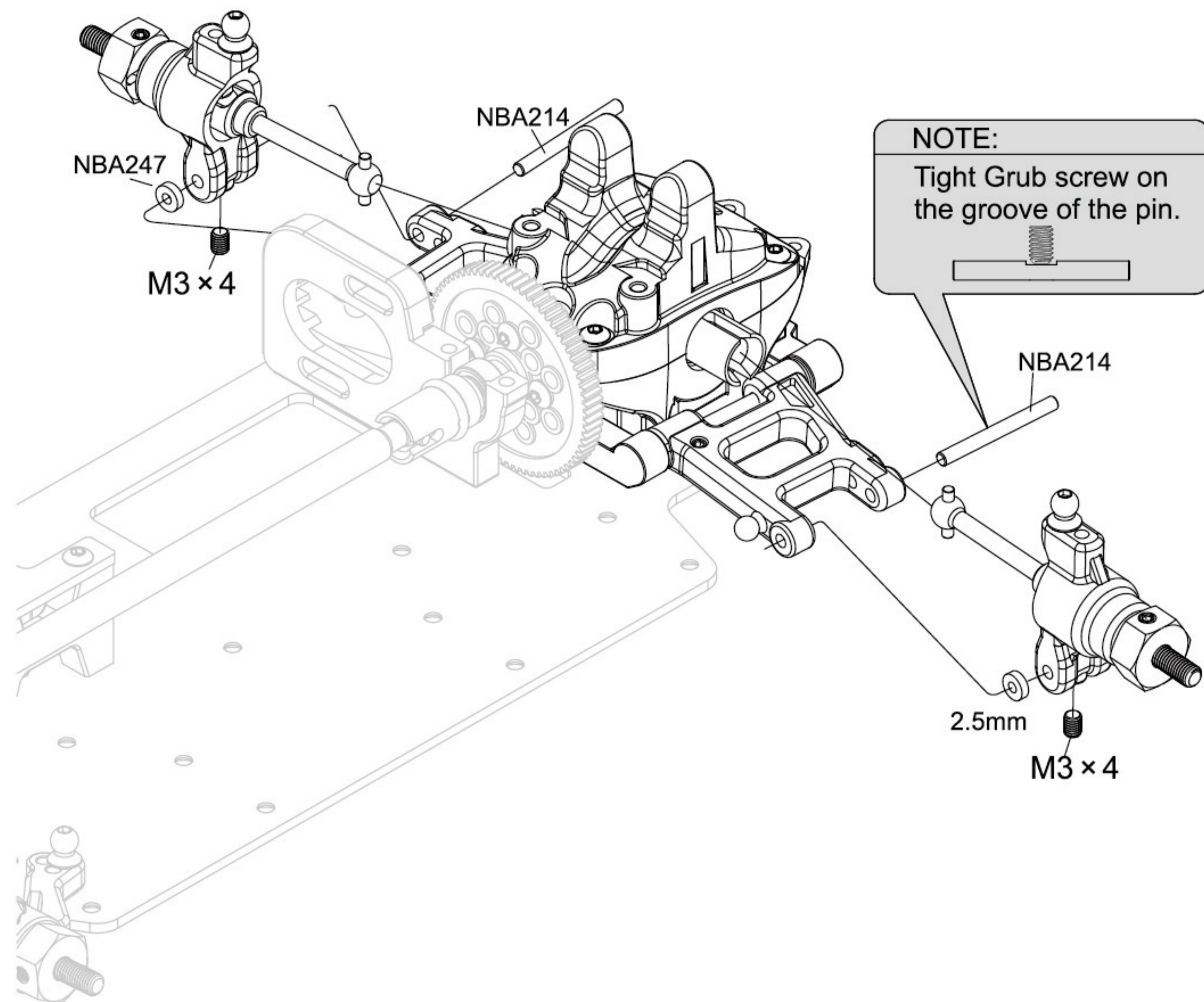

19

 X2

NBA283
M3×10mm

 X4

NBA282
M3×8mm

 X4

NBA210
3×8mm

 X2

NBA281
M3×6mm

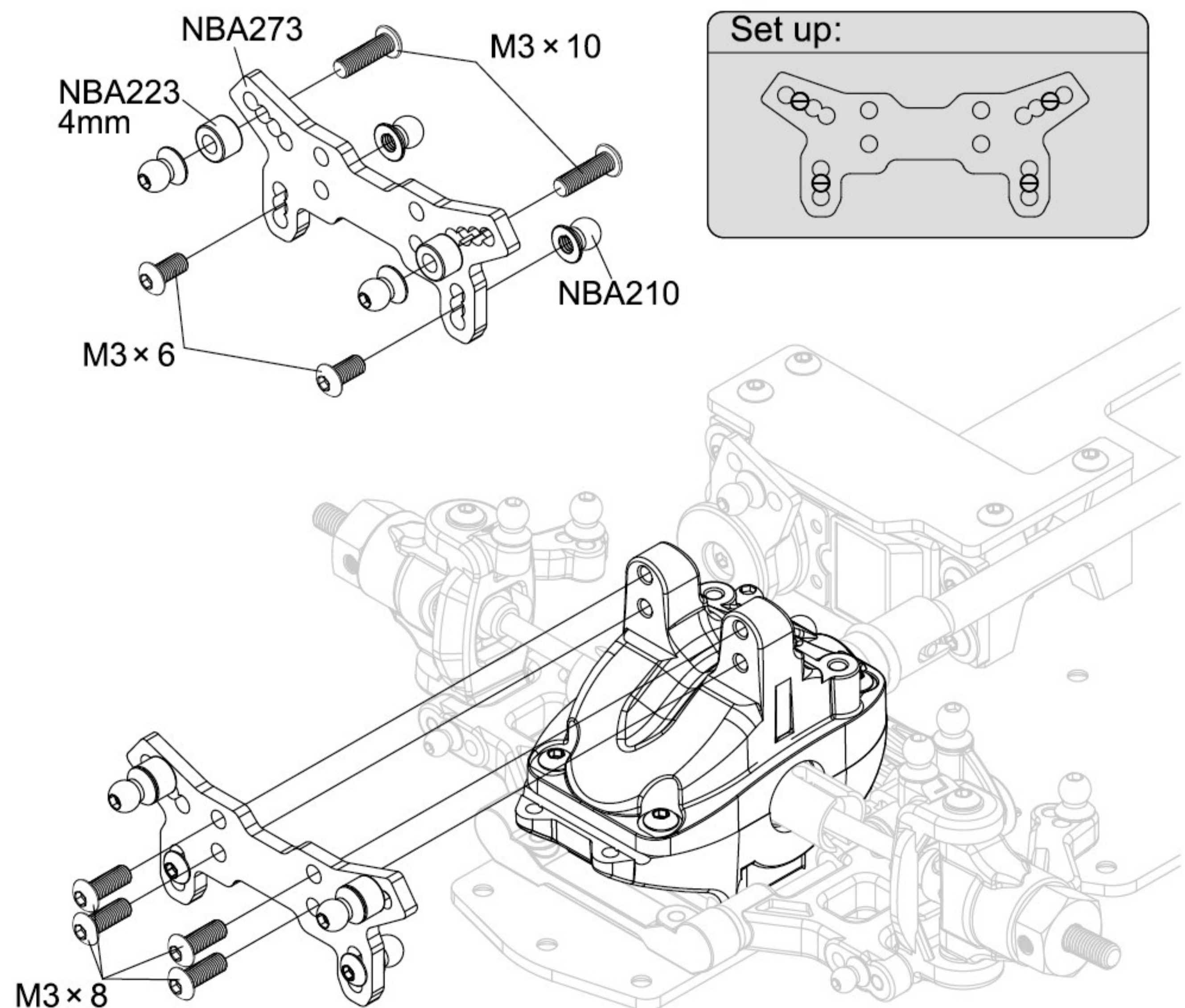

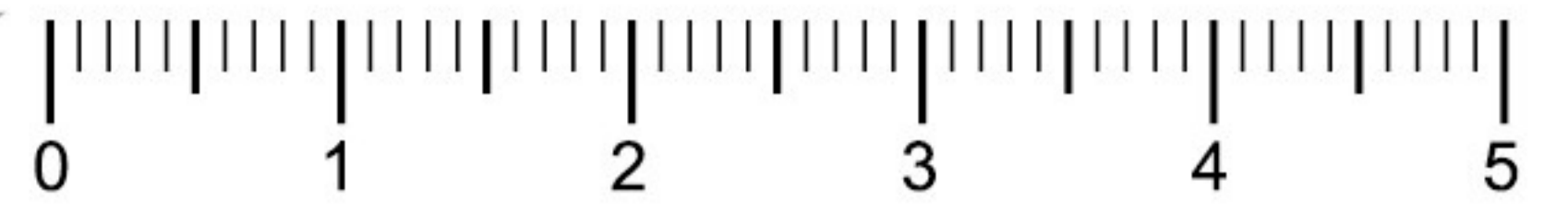

20

 X2

NBA283
M3×10mm

 X6

NBA282
M3×8mm



NBA210 X4
3×8mm

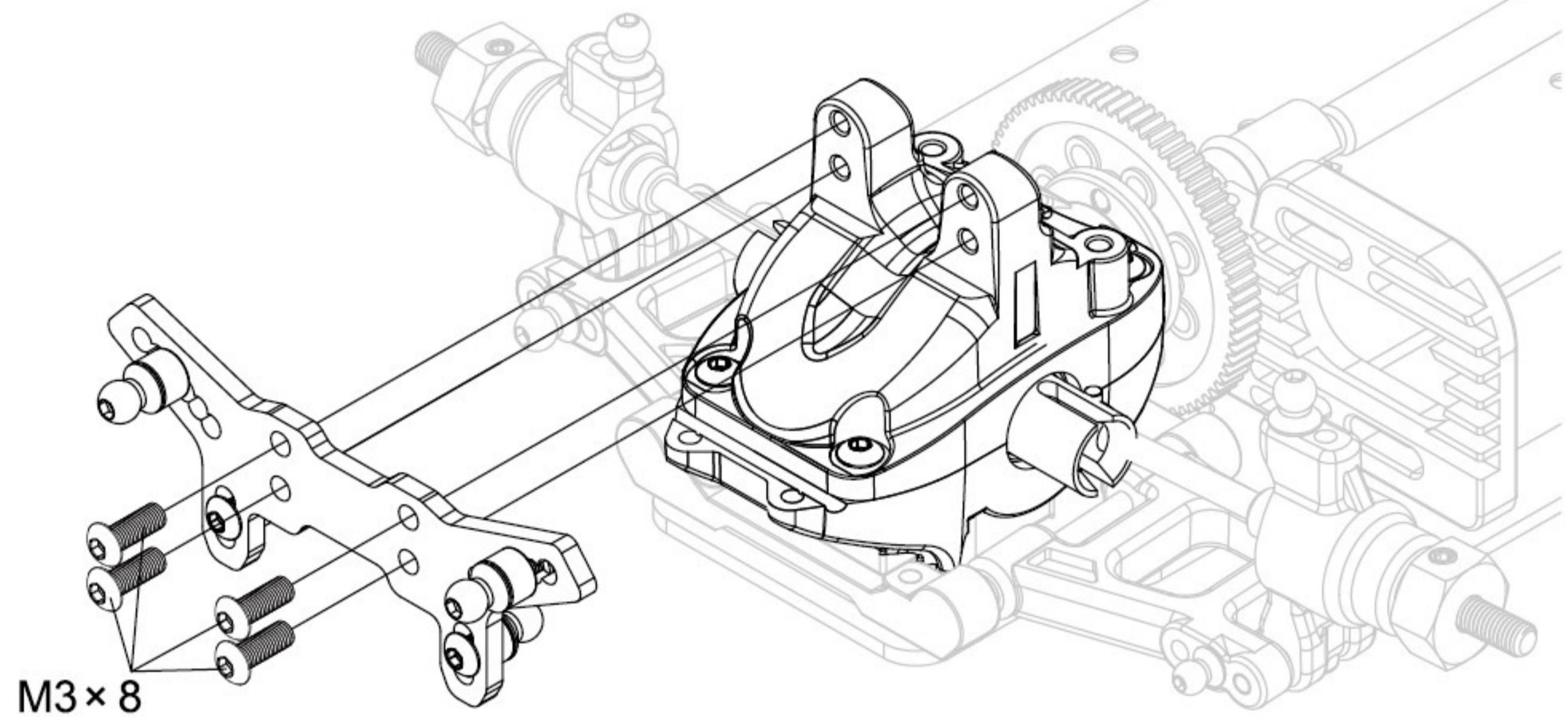
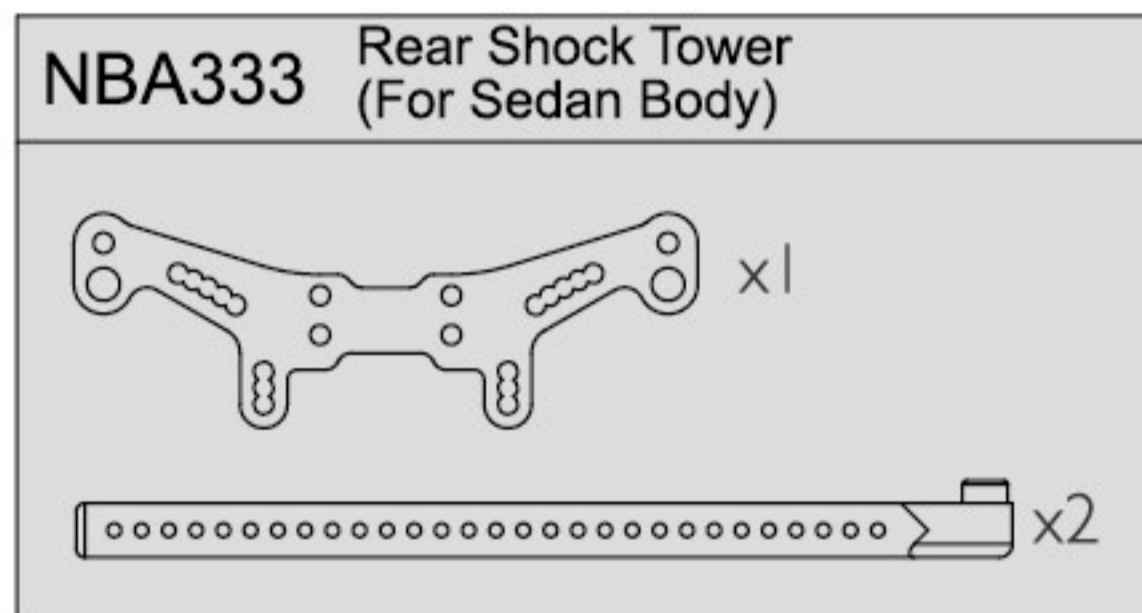
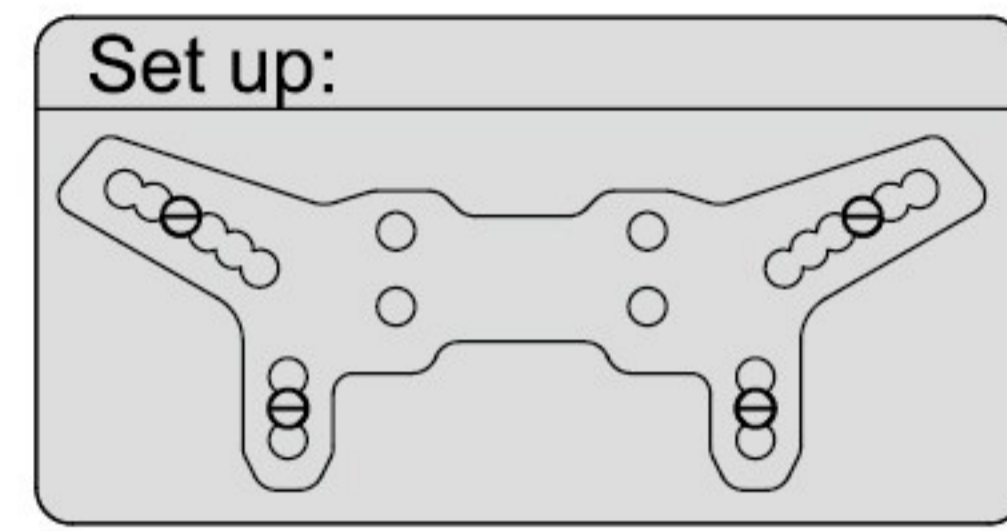
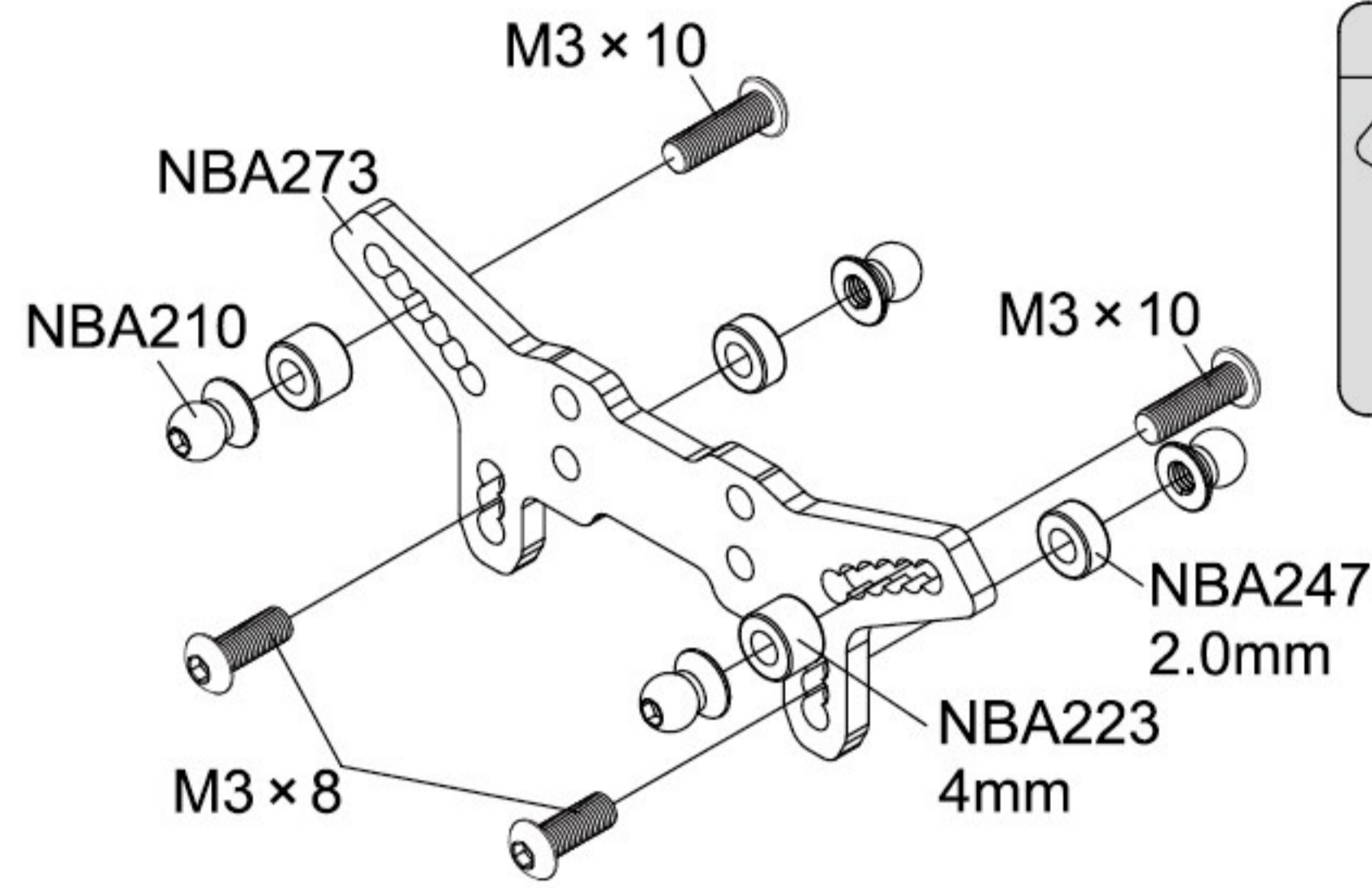

21

 X14

NBA247

 X2

NBA208
M3×12mm

 X4

NBA208
M3×19mm

 X1

NBA289
M3×8mm

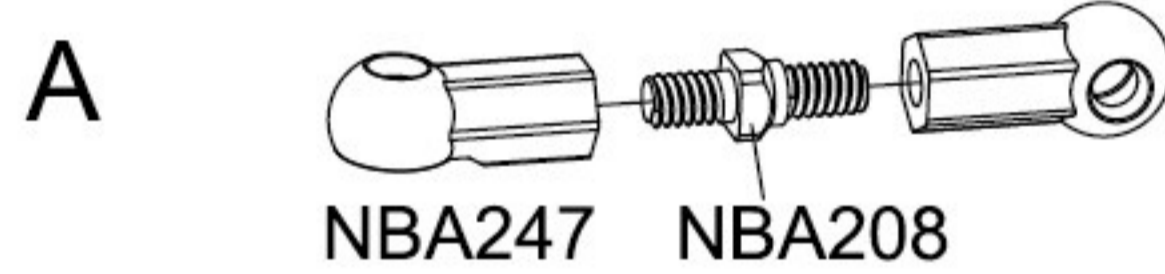

NBA247 NBA208

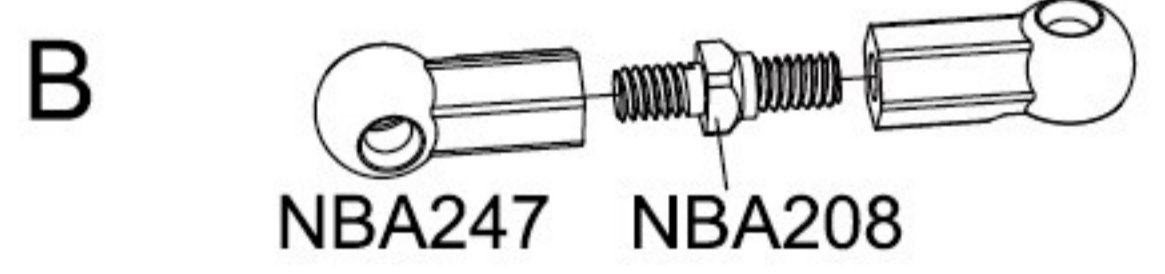
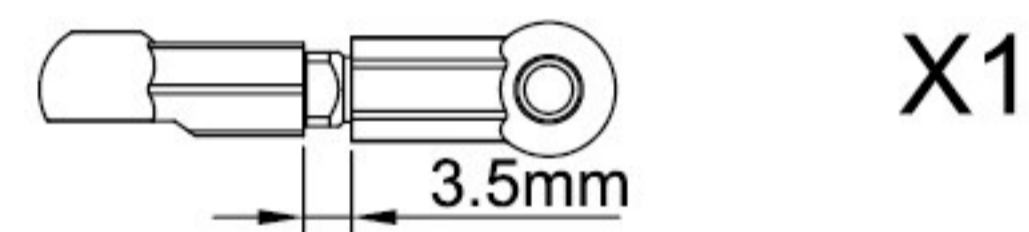

NBA247 NBA208

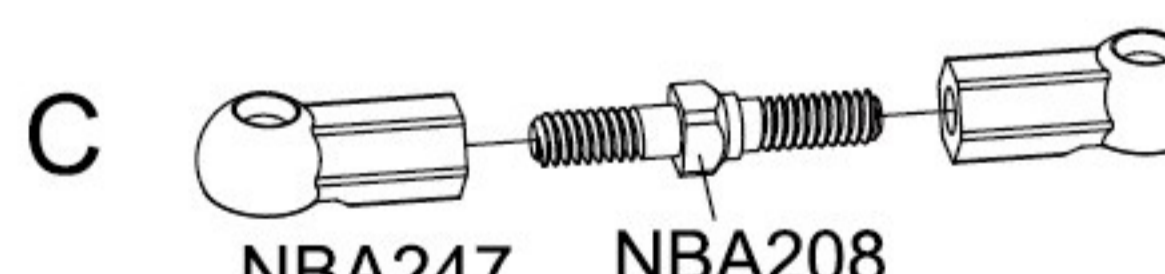
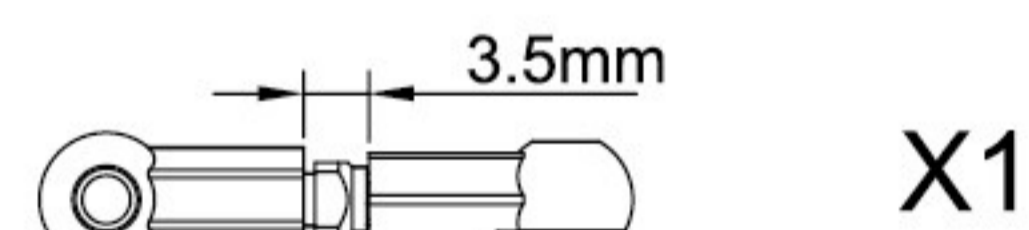

NBA247 NBA208

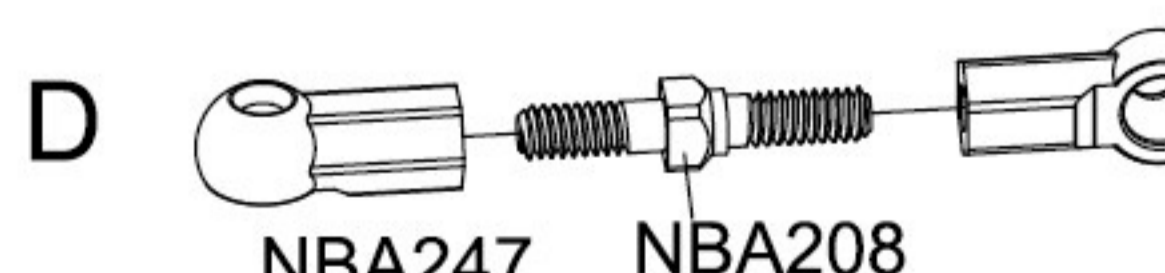
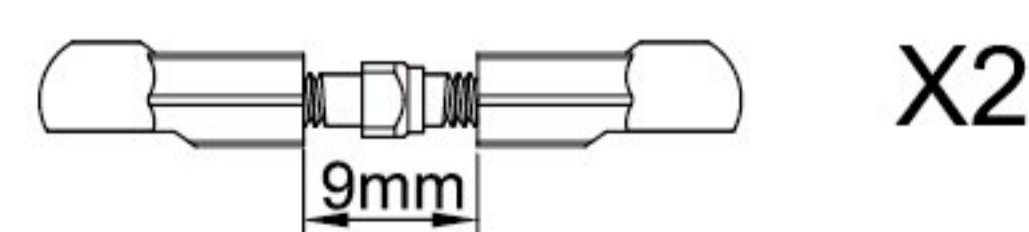

NBA247 NBA208

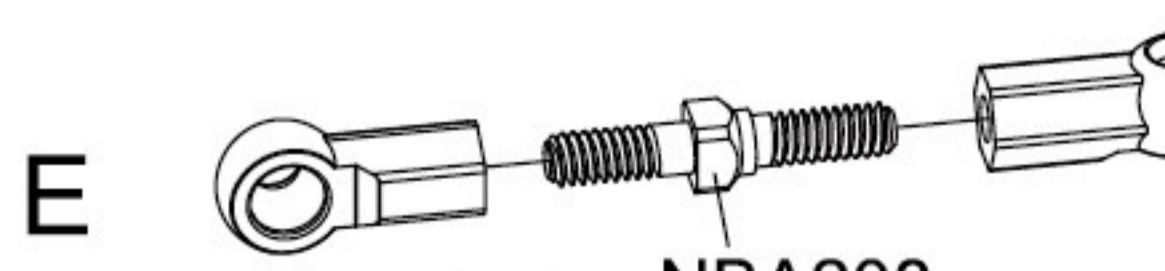
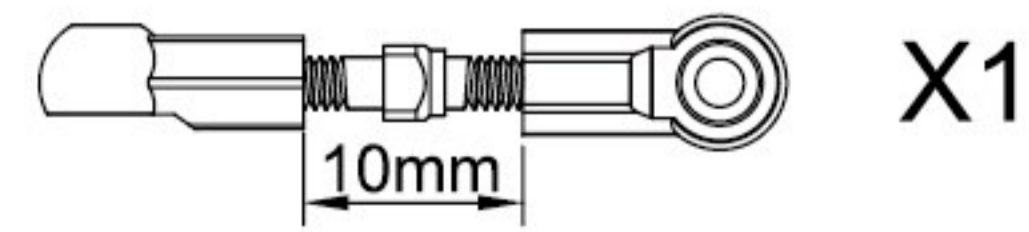

NBA247 NBA208

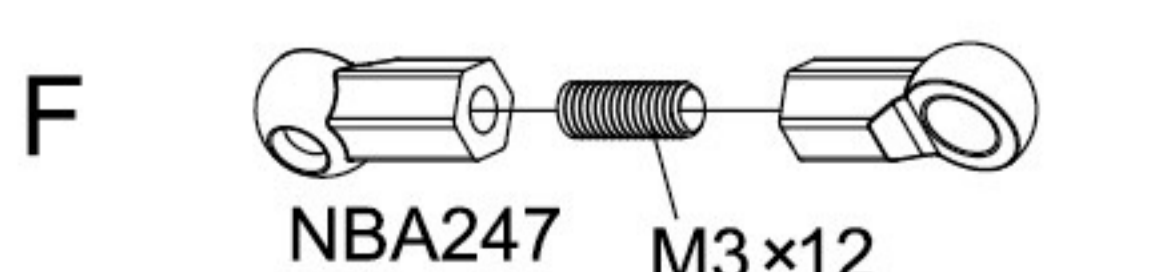
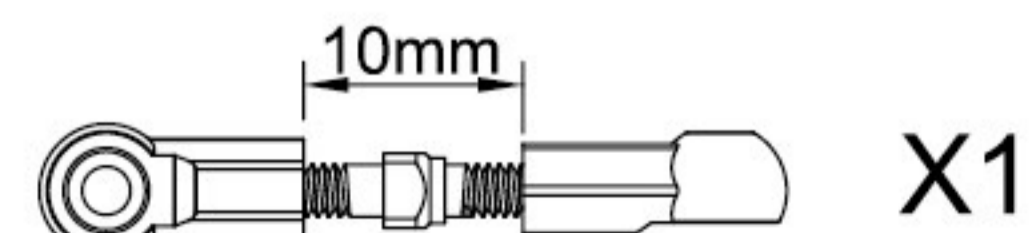

NBA247 M3×12

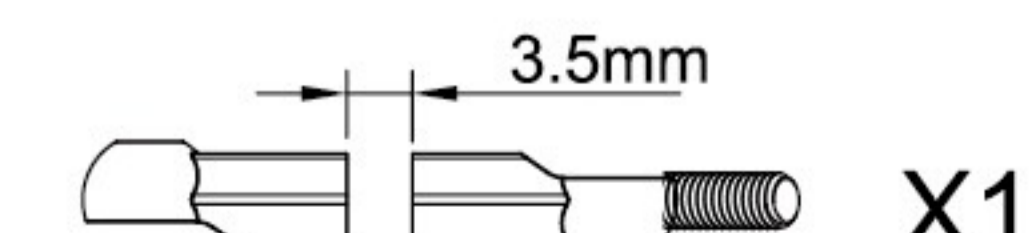

22

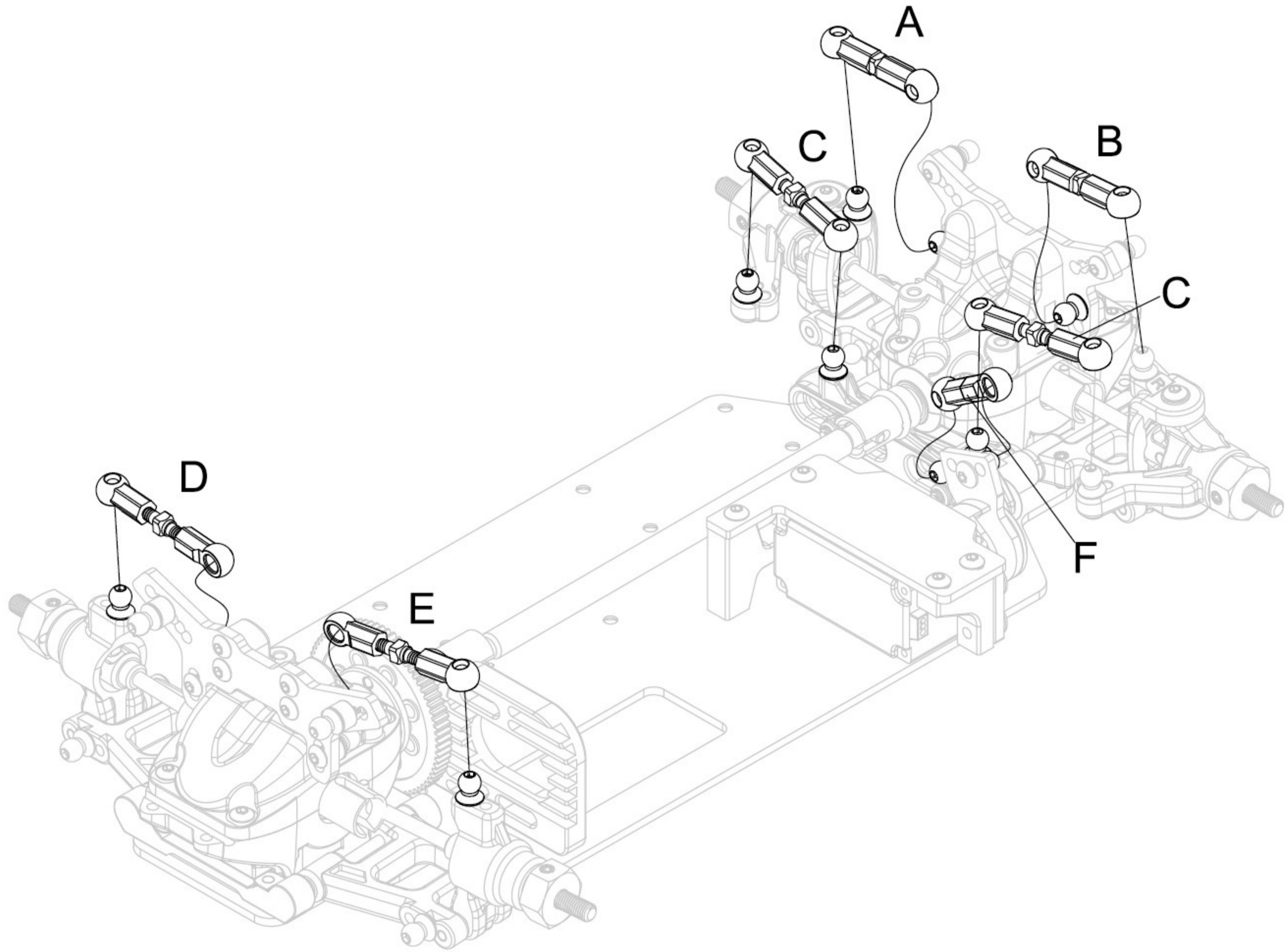

23

 X6

NBA279
M3×6mm

 X4

NBA281
M3×6mm

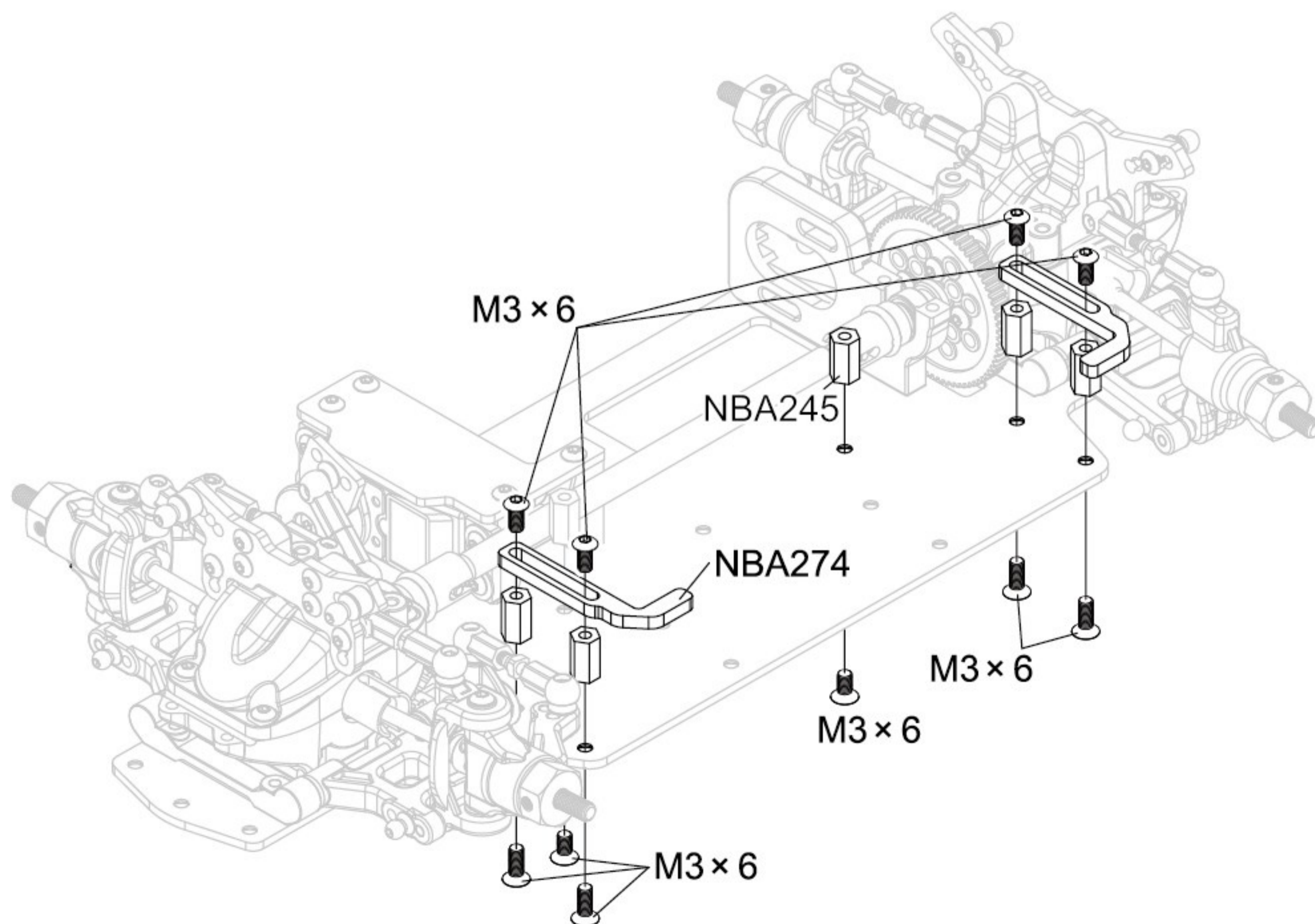

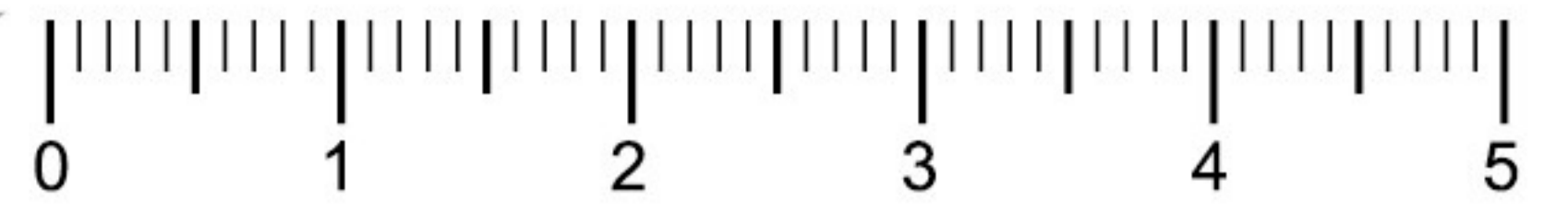

24

 X4

NBA282
M3×8mm

 X2

NBA285
M3×18mm

 X4

NBA283
M3×10mm

 X1

NBA288
M3×4mm

 X9

NBA281
M3×6mm

OPTION

NBA356 Extended Body Post(6mm)

 X4  X4

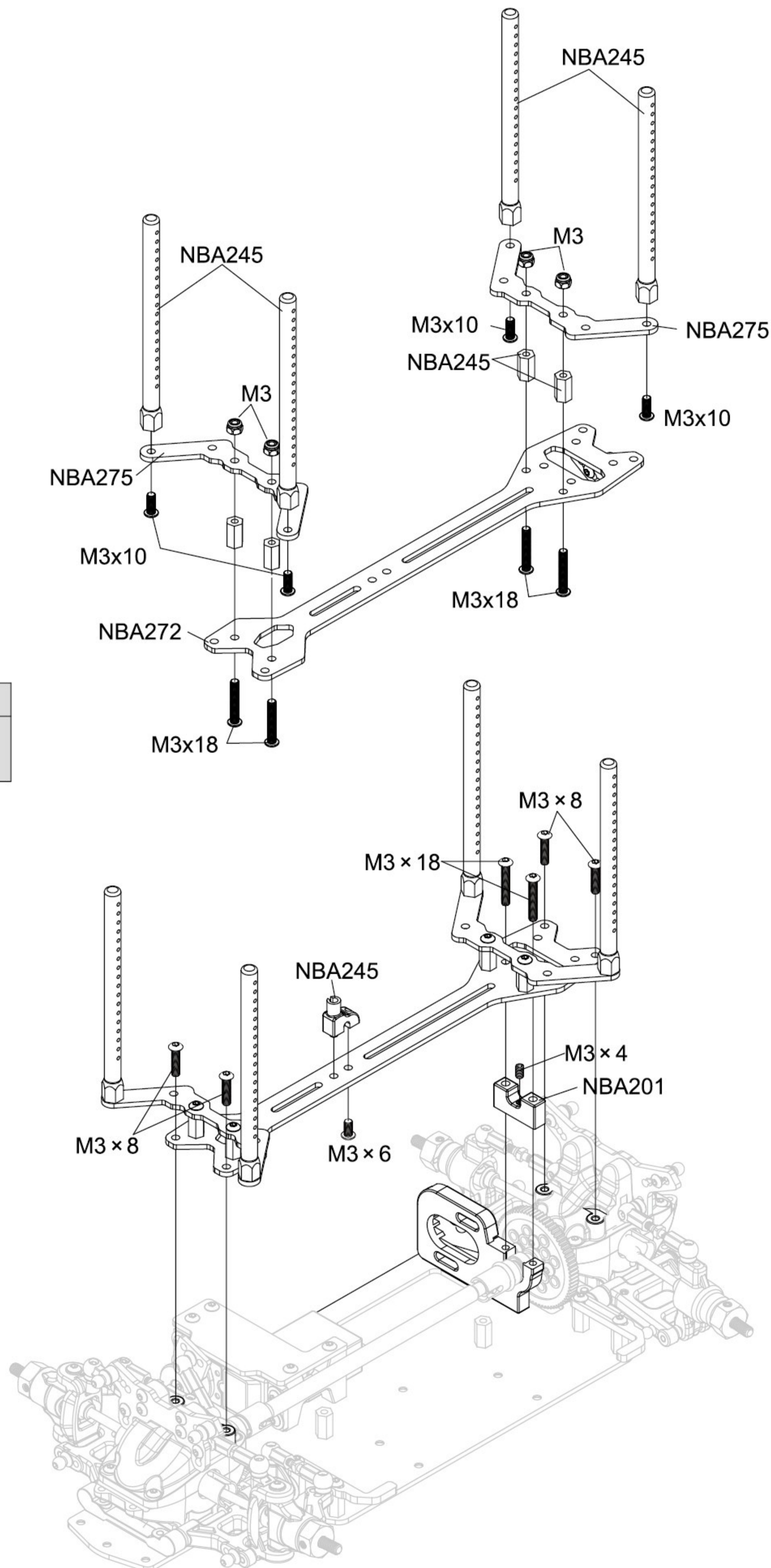

25

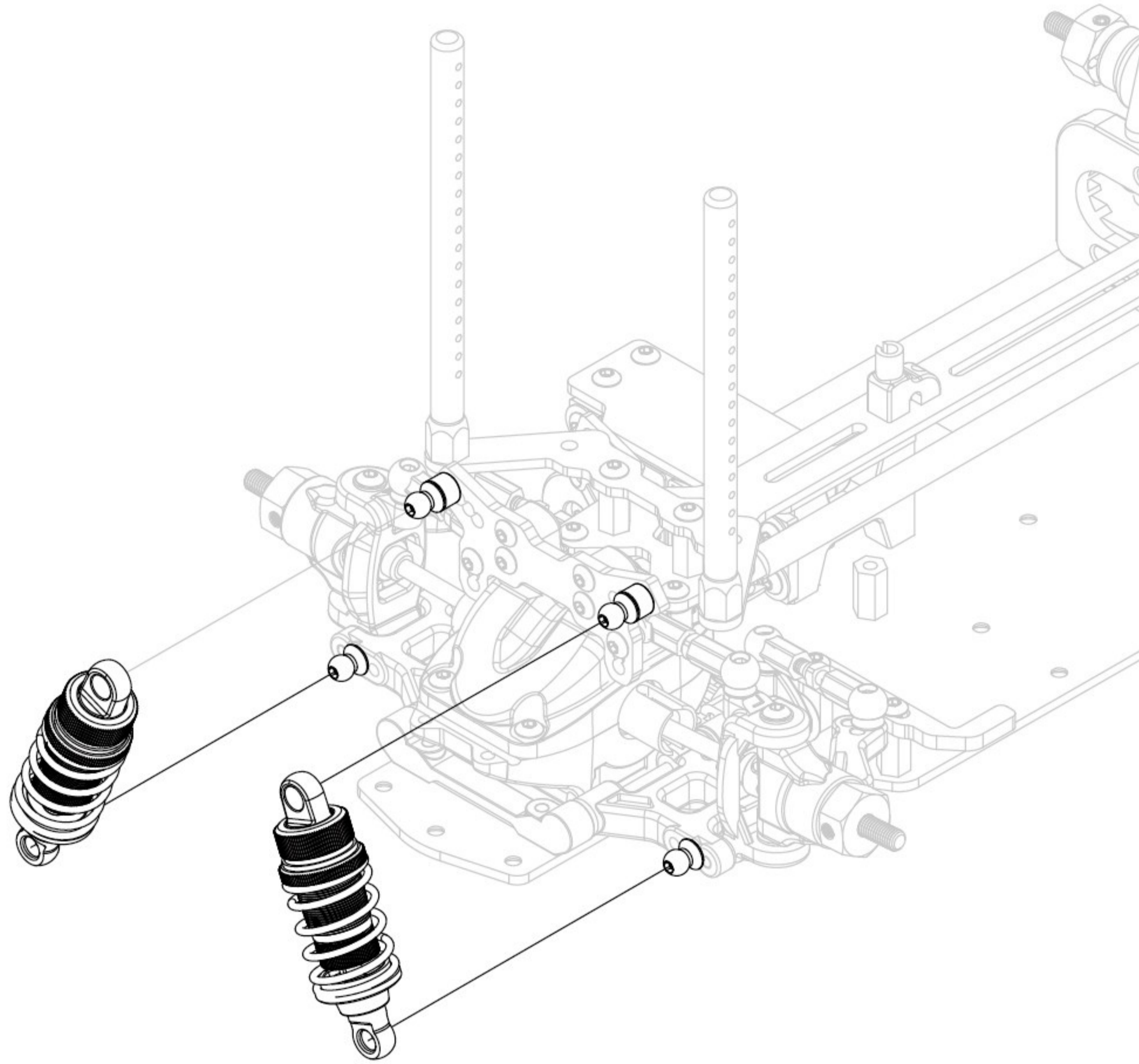

26

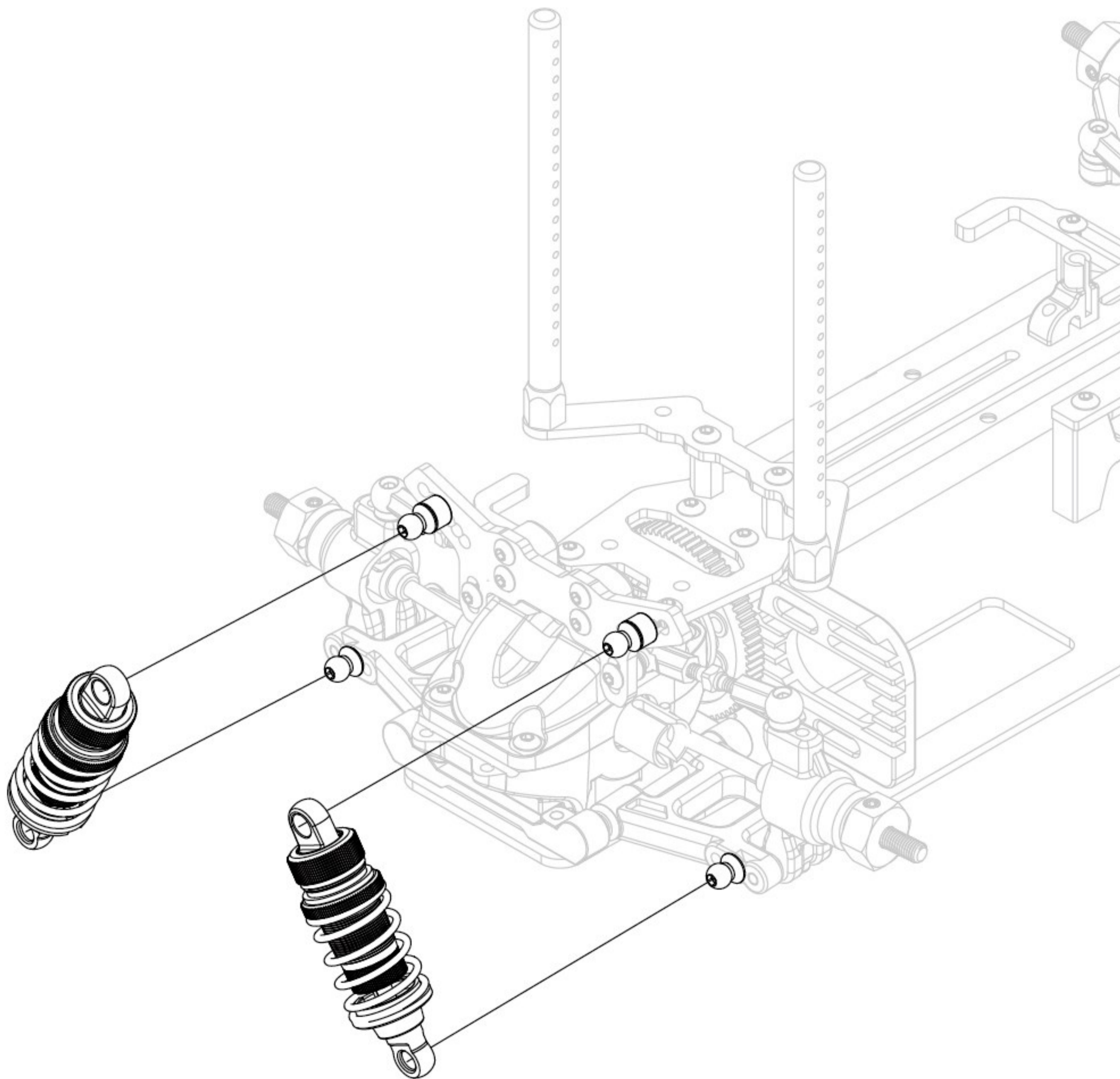

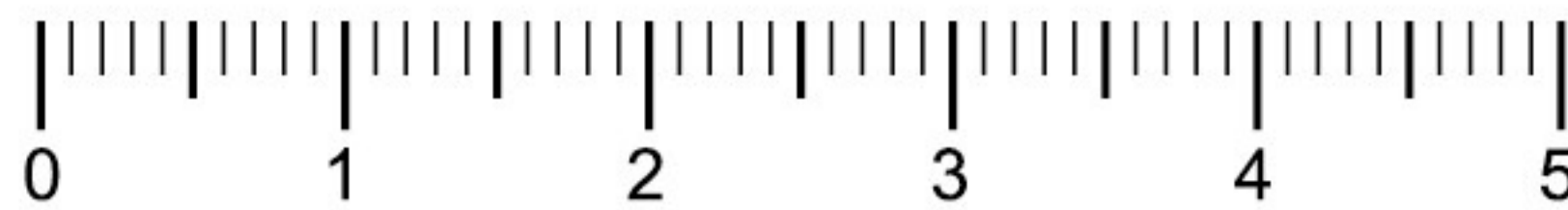

27

 X3

NBA280
M3×8mm

 X2

NBA282
M3×8mm

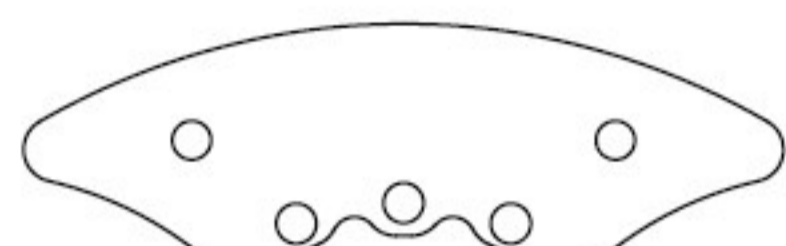

NBA256



NBA257

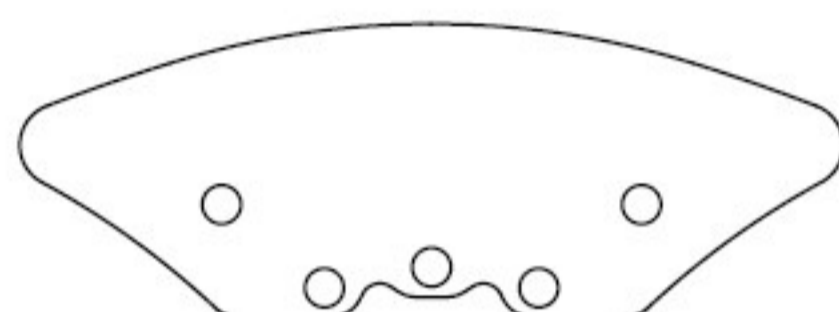

NBA336

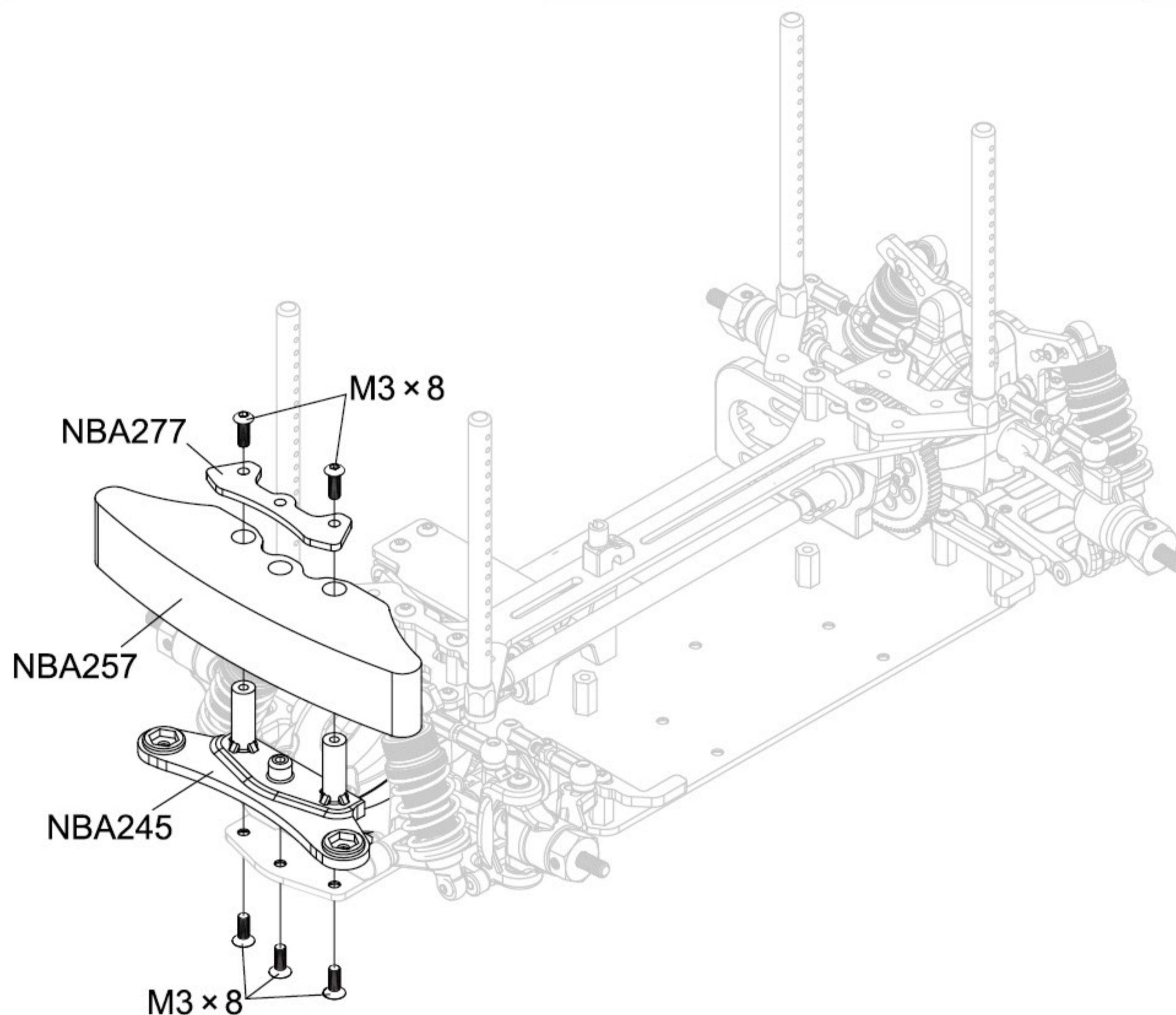

28

 X2

NBA283
M3×10mm

 X2

NBA302
3×8×0.5

 X1



NBA287
M3×3mm

Ball differential recommend use 17.5T
Brushless or 23T~27T Brushed Motor
If more power output, option Metal Ball
Differential (NBA309) or Gear Differential Set
(NBA310)

NBA215 39T-48P Pinon Gear(Aluminum)

 x1  x1



NBA216 31T-48P Pinon Gear(Metal)

 x1  x1

NBA217 31T-48P Pinon Gear(Aluminum)

 x1  x1

NBA218 27T-48P Pinon Gear(Metal)

 x1  x1

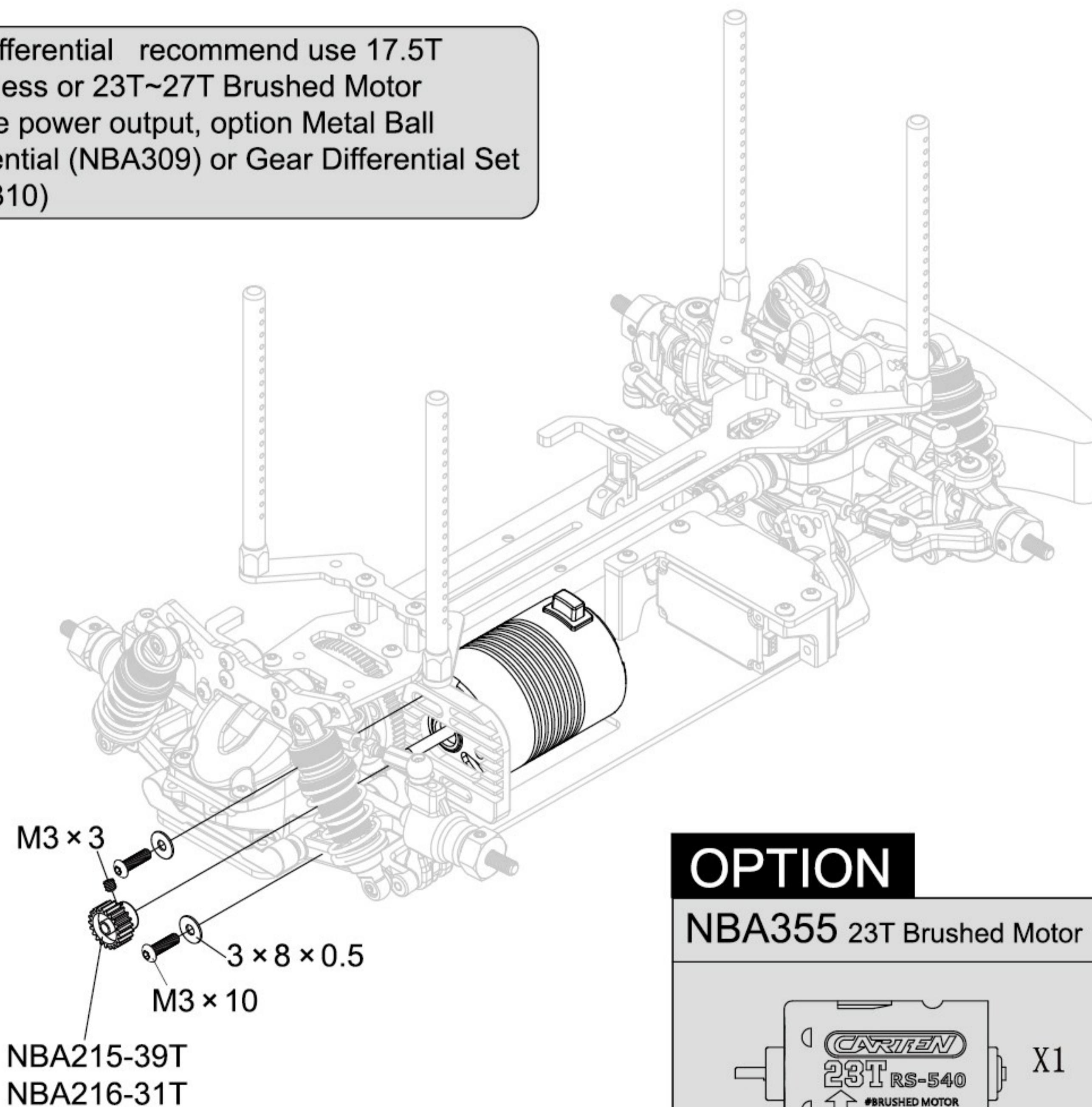

OPTION

NBA355 23T Brushed Motor

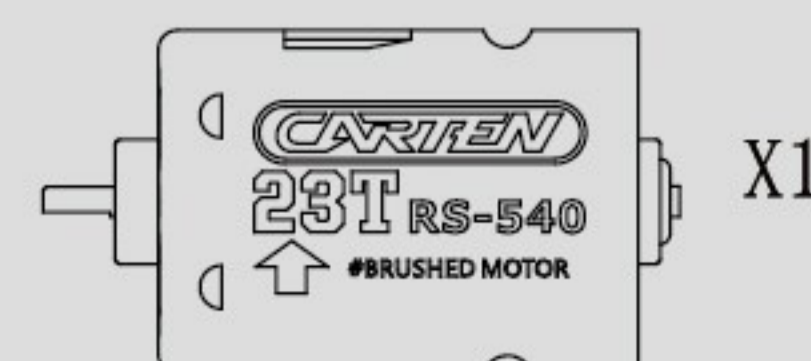

X1

29

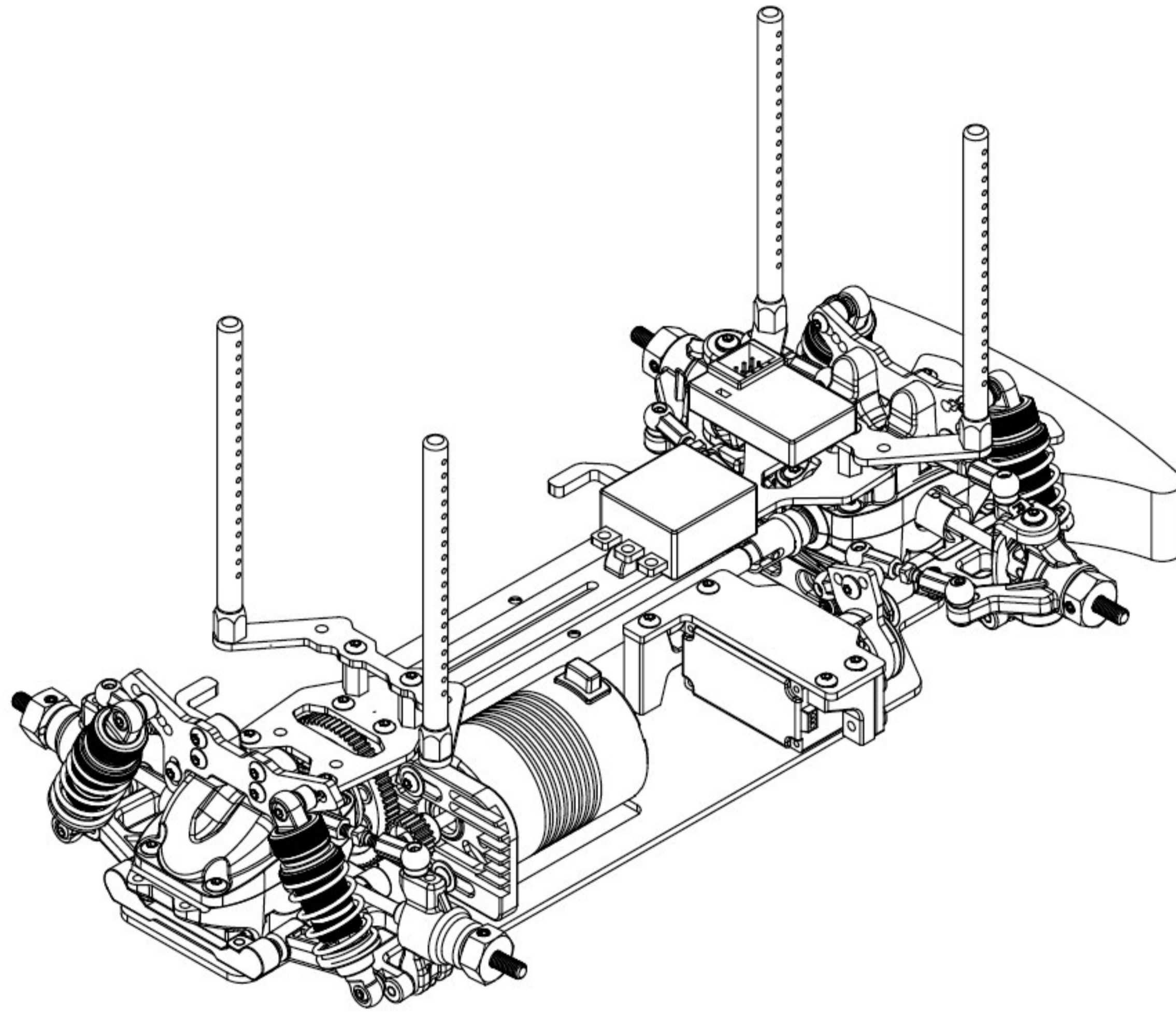

30



X4

NBA295
M4

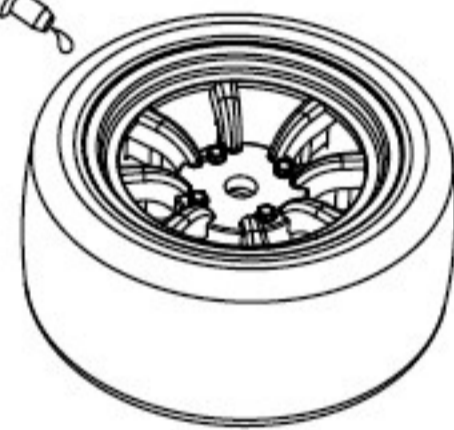

X4

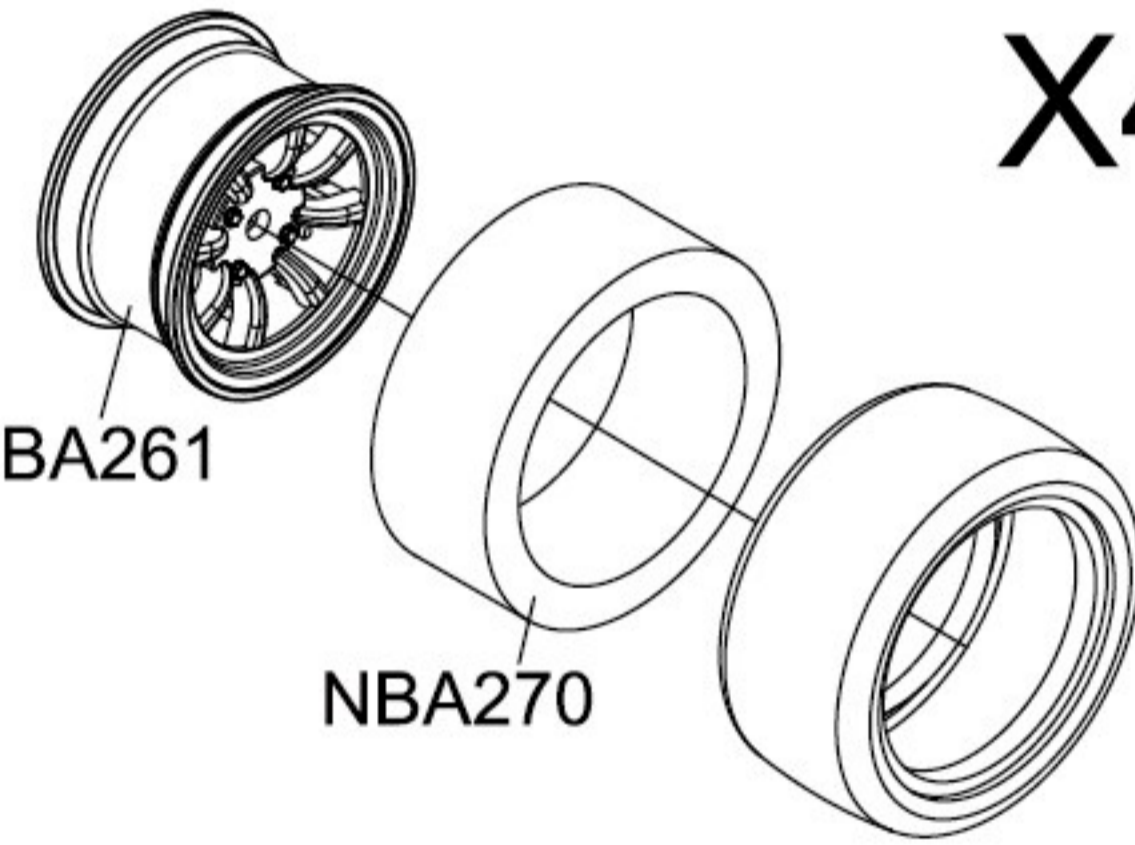

NBA328 M-Drift Tires

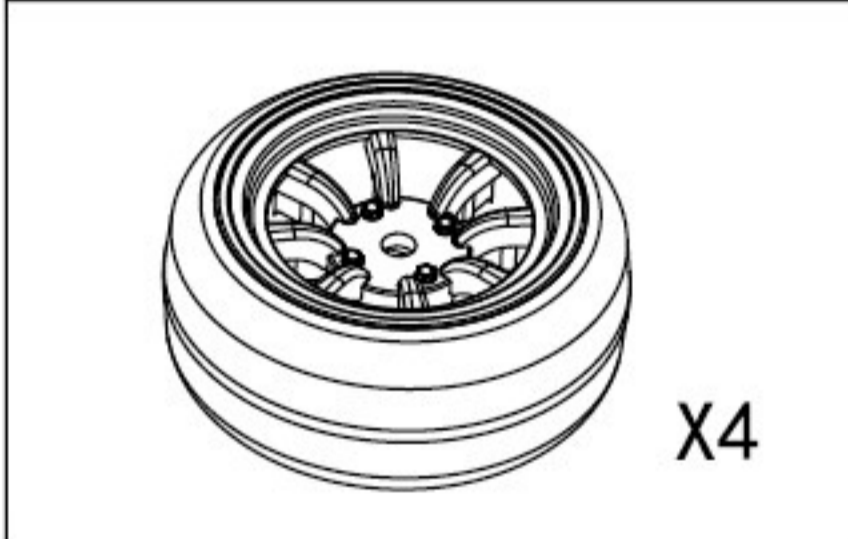

M4

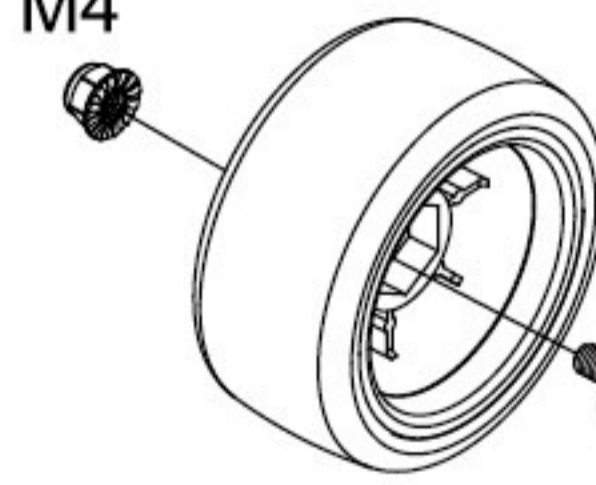

M4

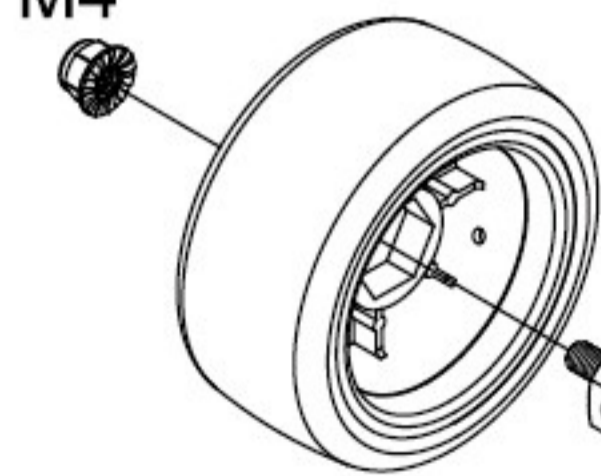

NBA330 M-Rally Tires

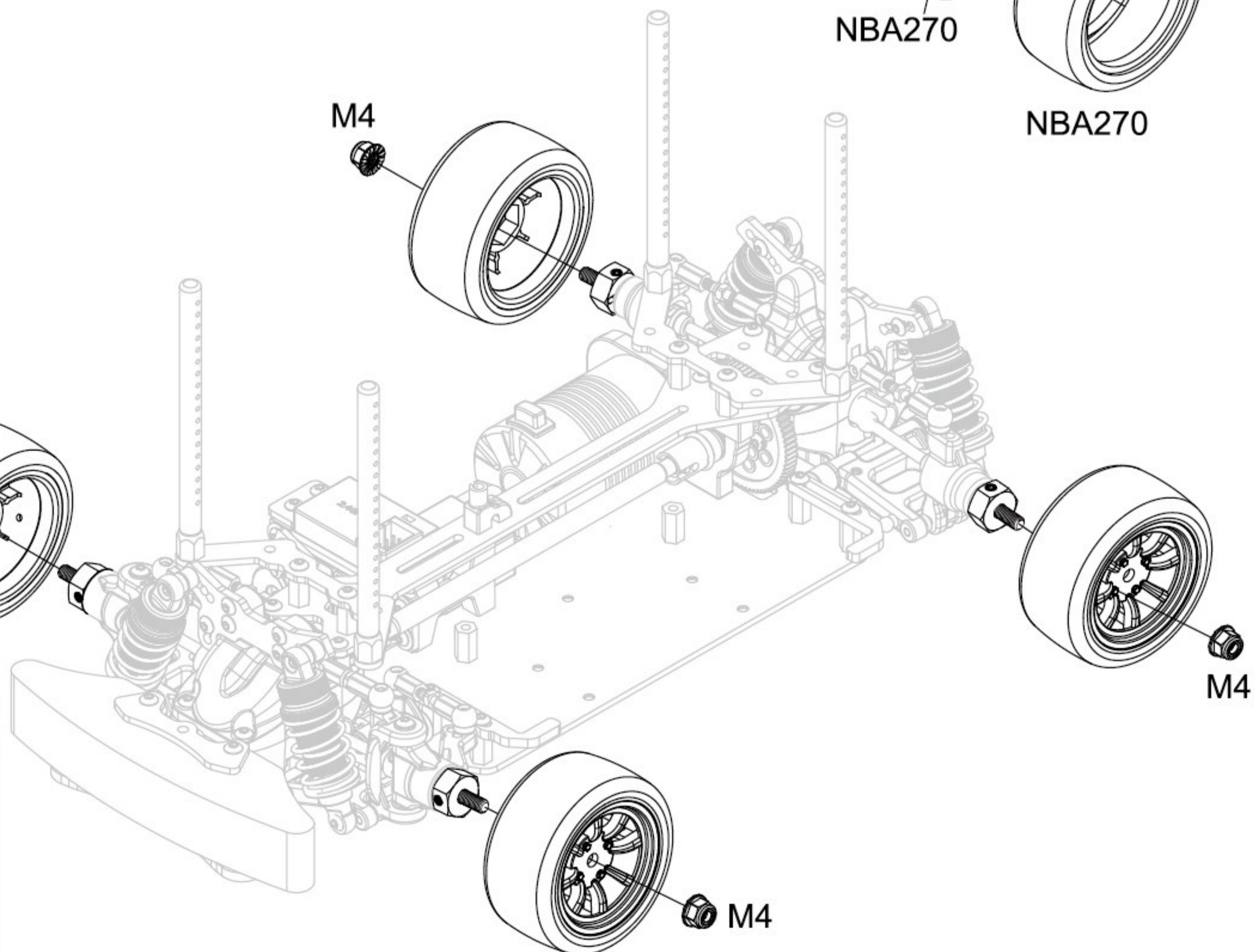
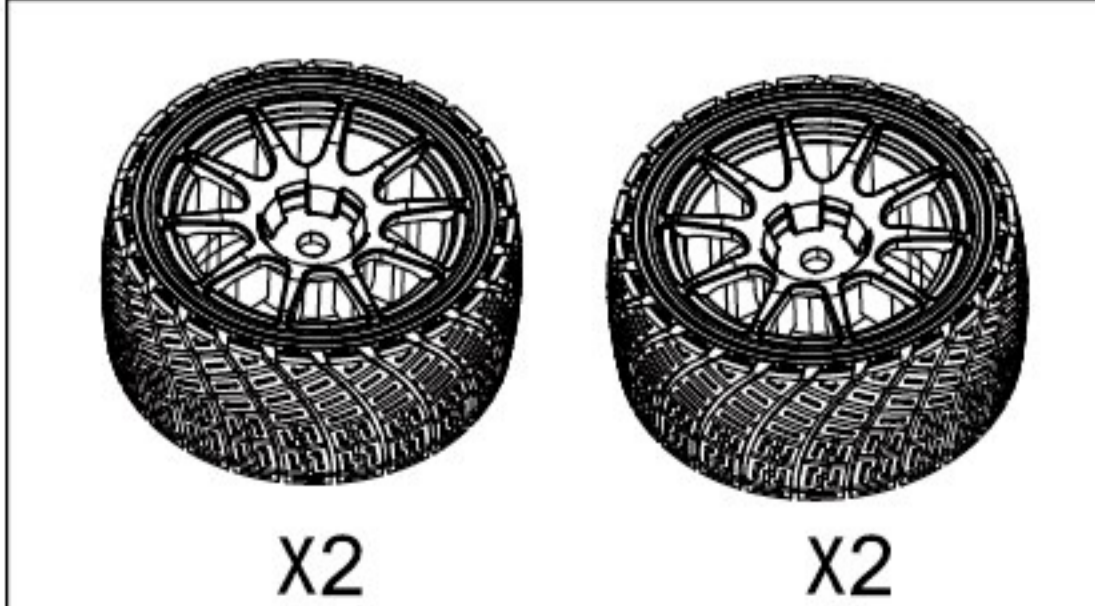

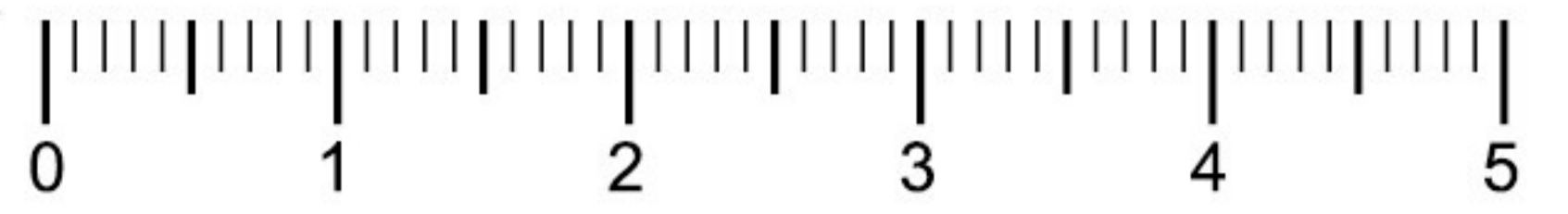

31

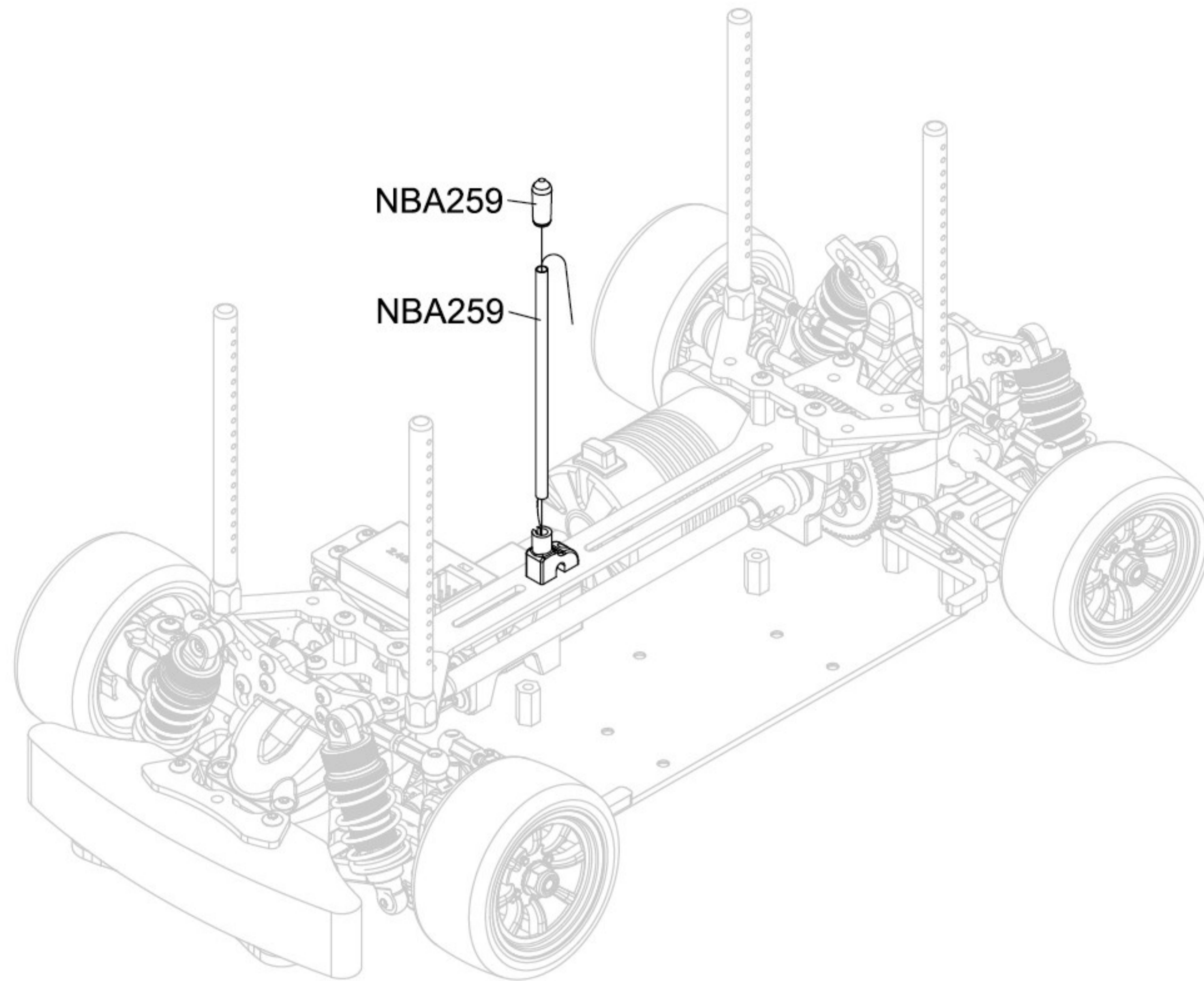

32

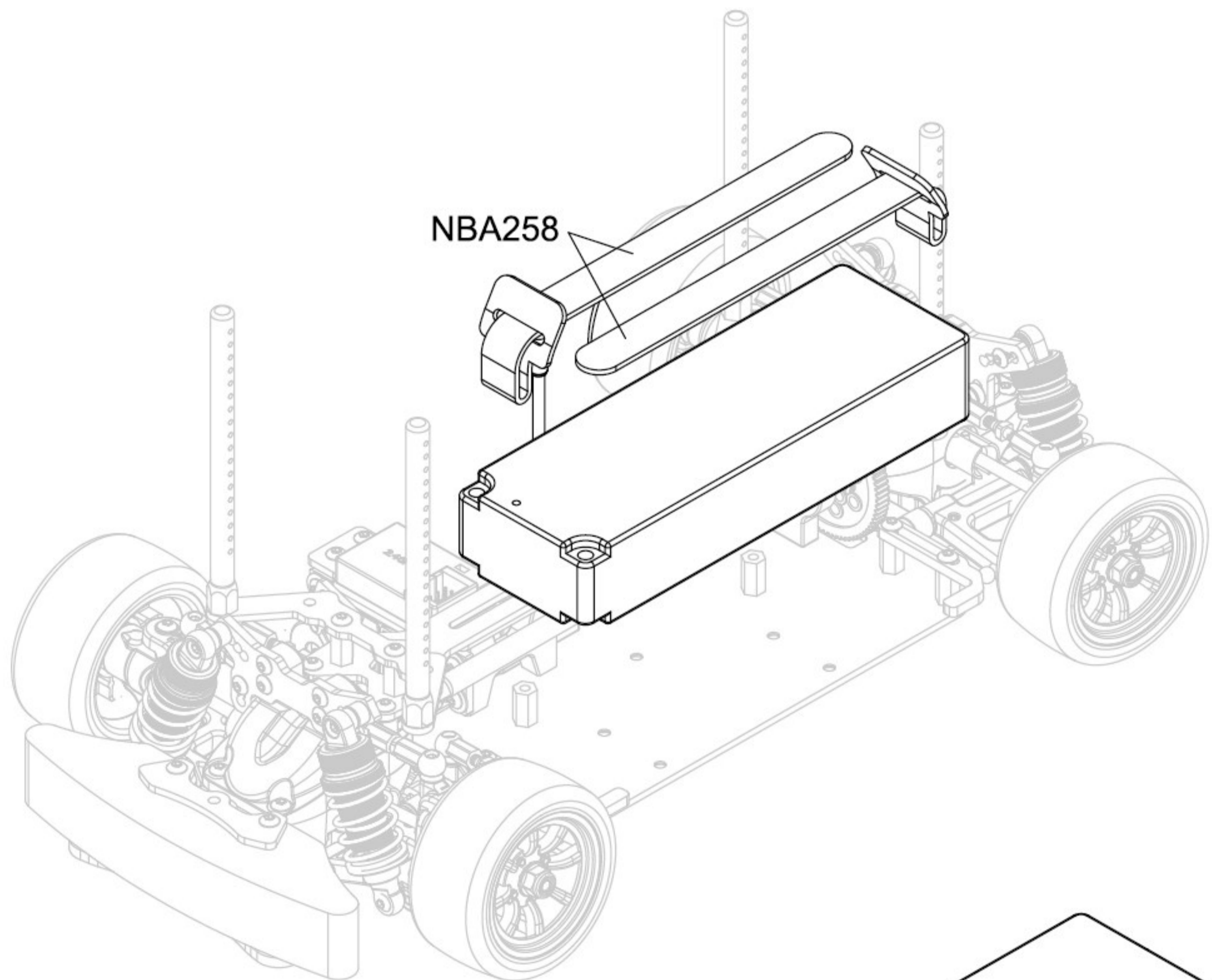
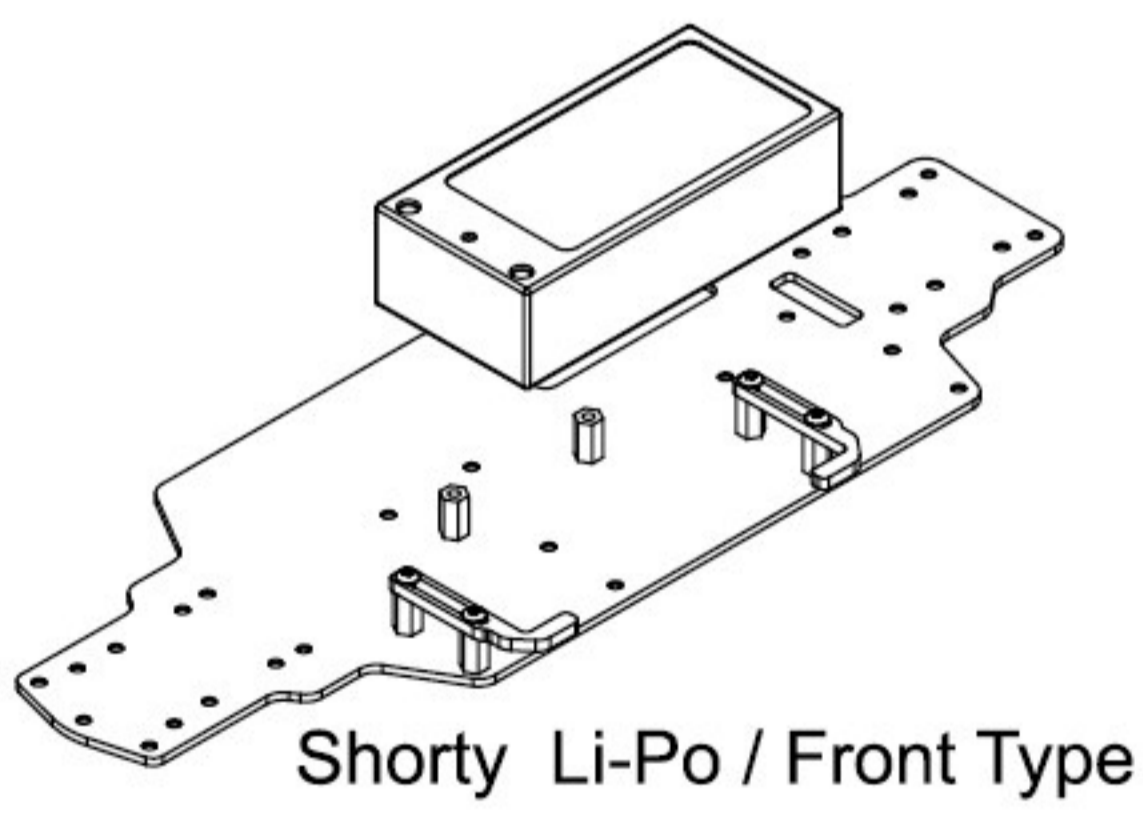
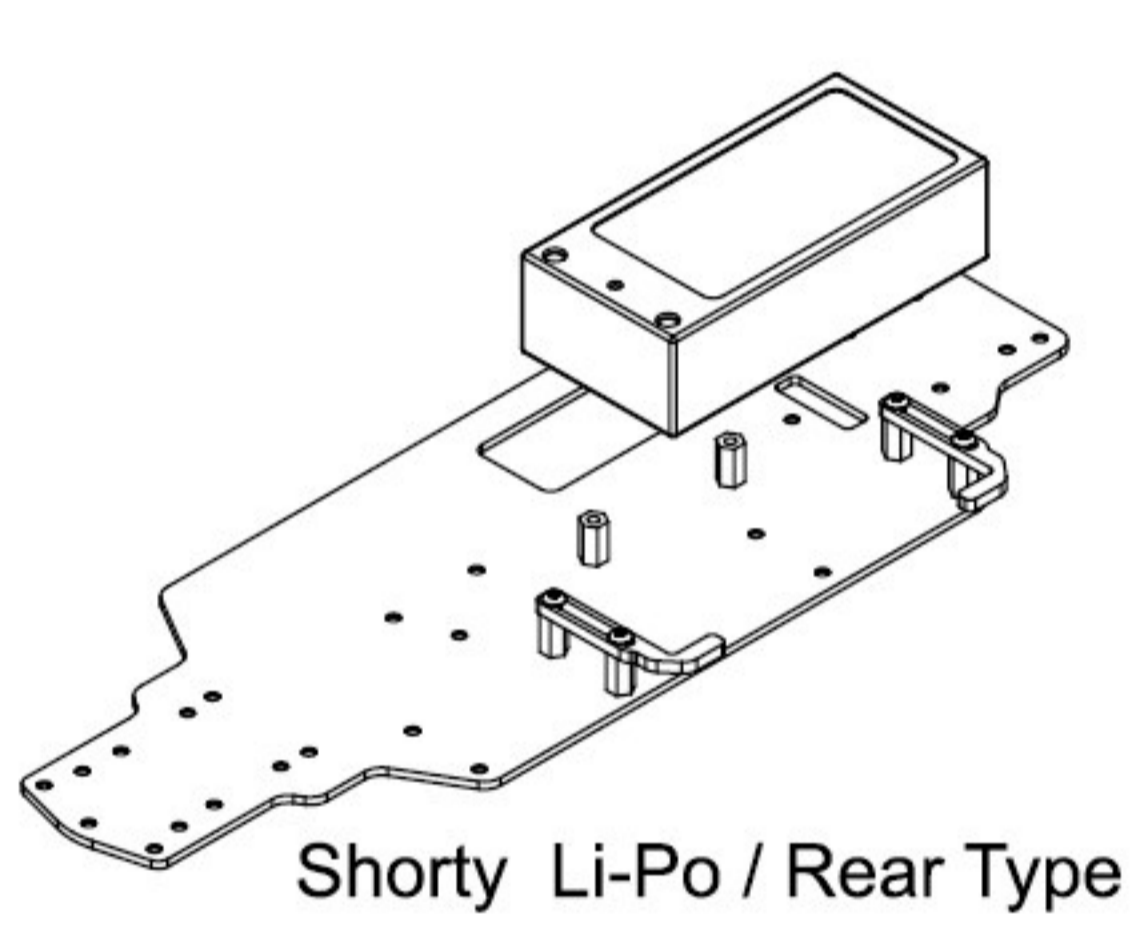

Front

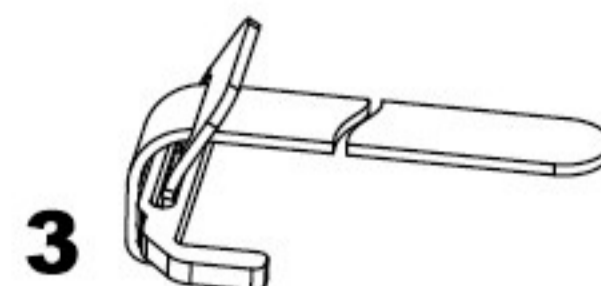
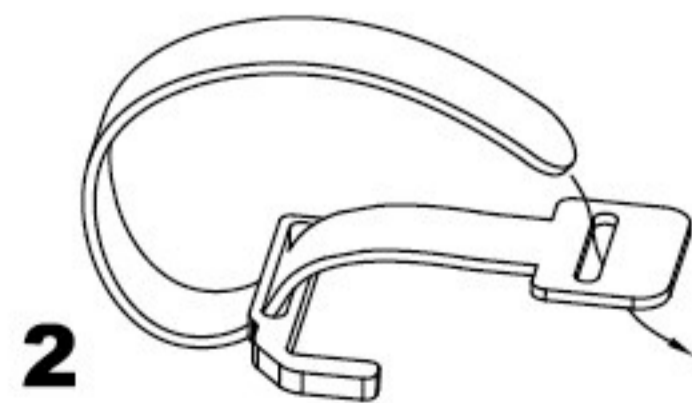
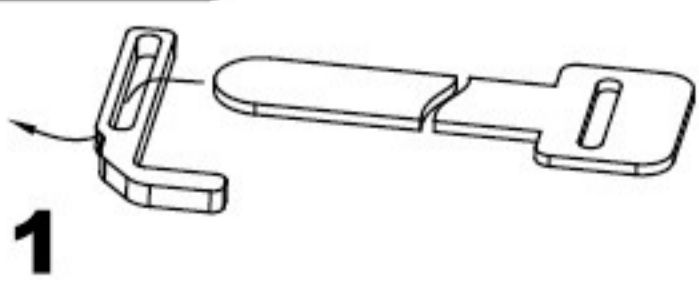

Rear

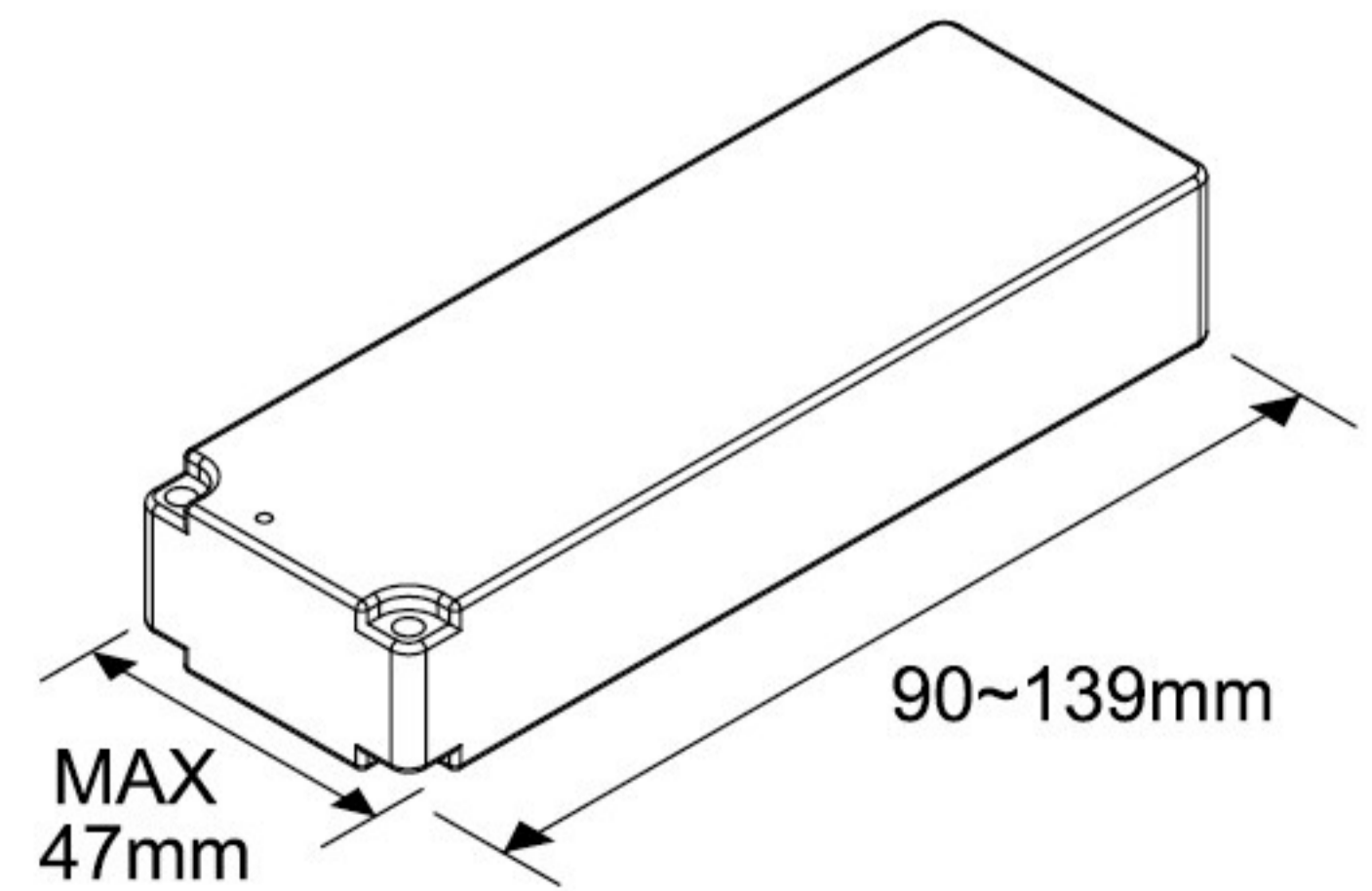
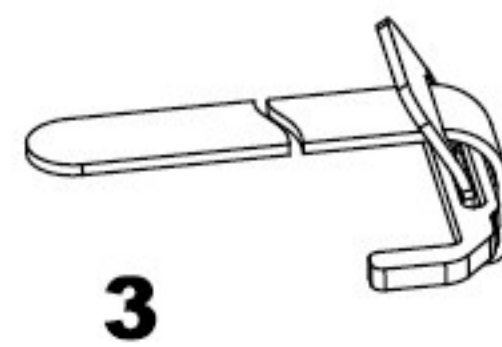
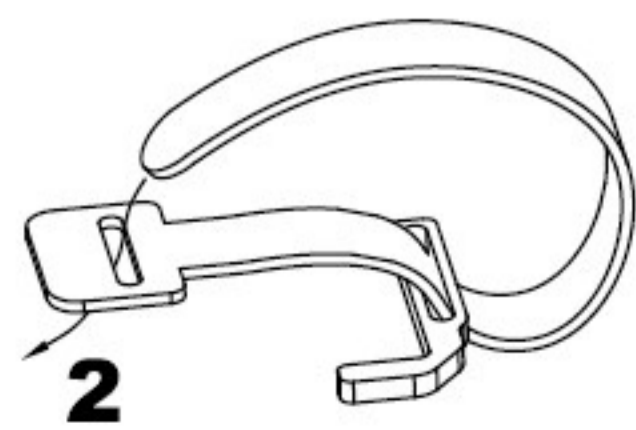
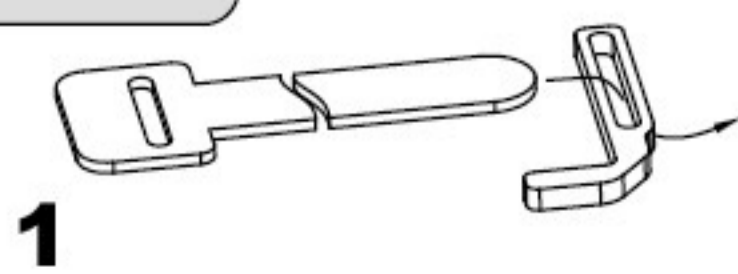

33

 X8
NBA305

NBA305

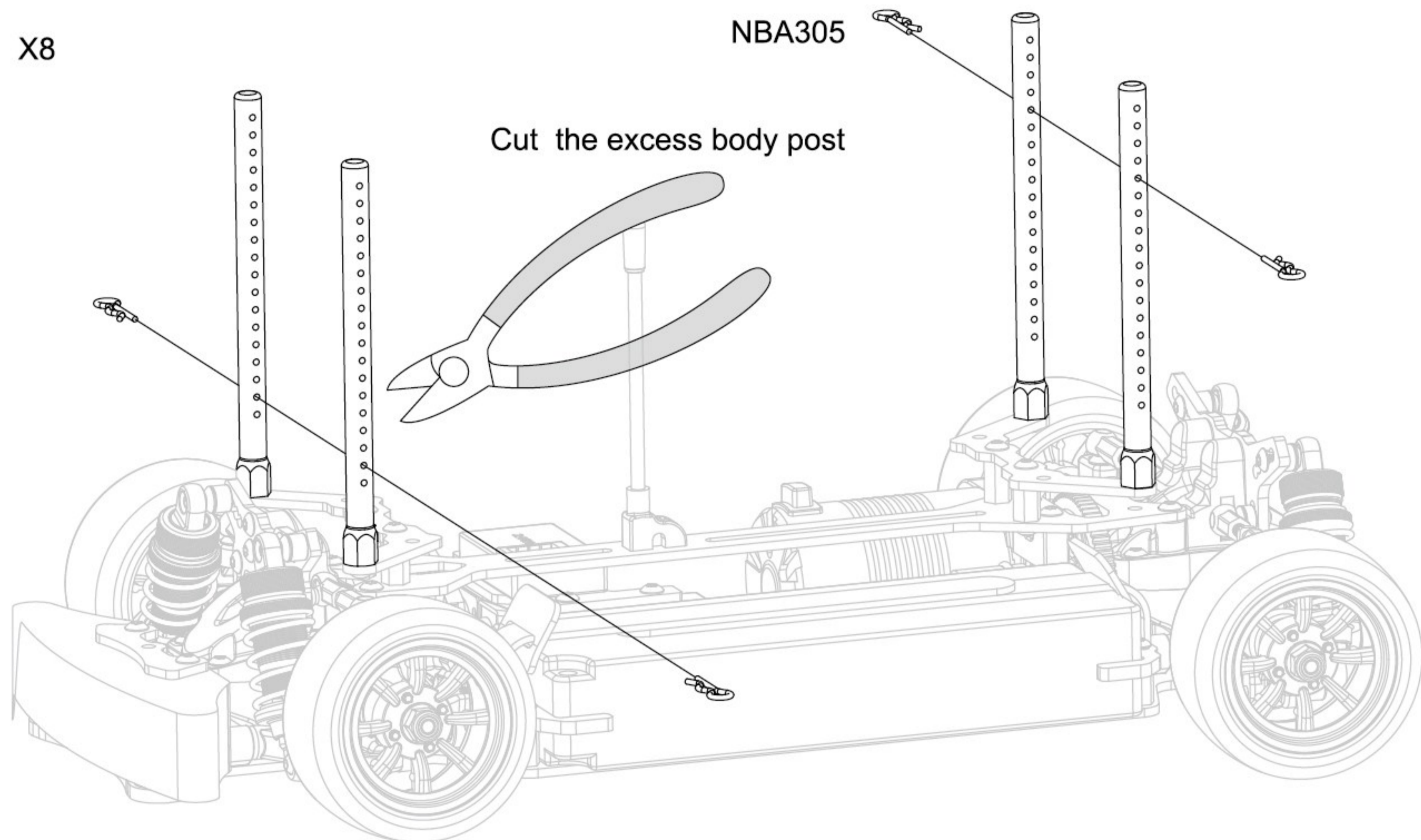

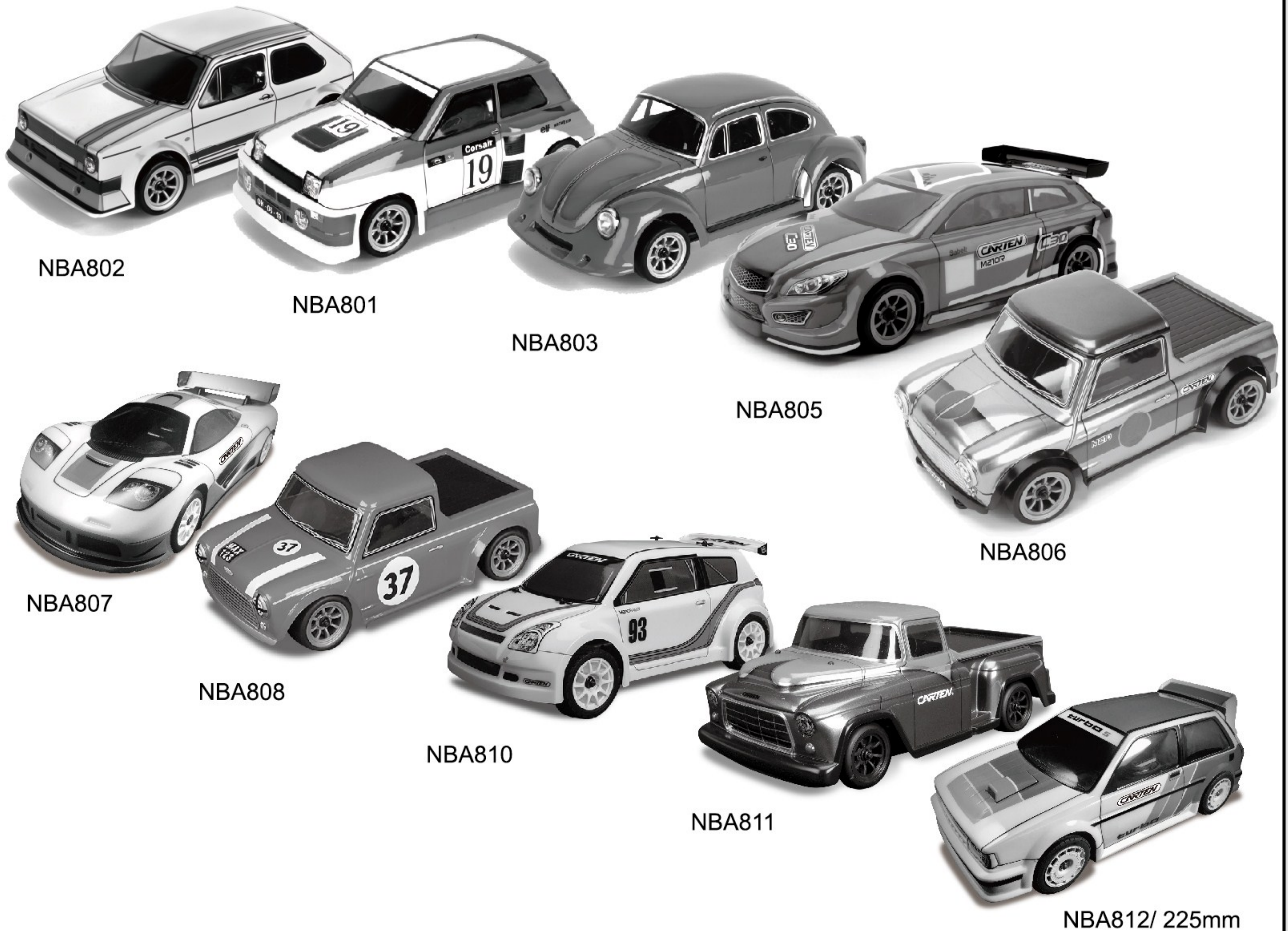

M210 Body

210mm Wheelbase Body



OP

Option Parts Assembly Manual

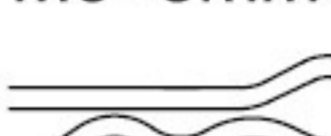
-  X3
NBA280
M3×8mm
-  X2
NBA282
M3×8mm
-  X8
NBA305

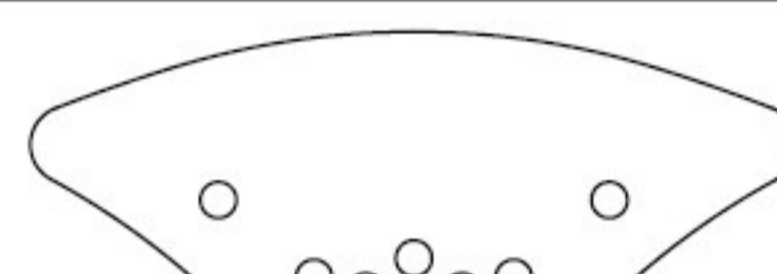
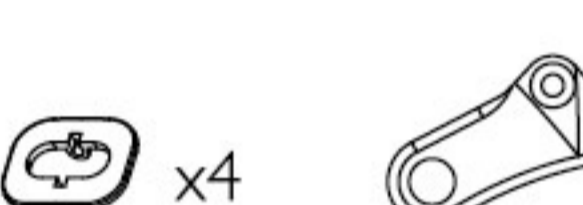
- NBA278** Bumper Plate (For Sedan Body)
 x1
- NBA336** Bumper For Touring Car Body
 x1
- NBA337** Bumper Plate & Body Post Spacer
 x4

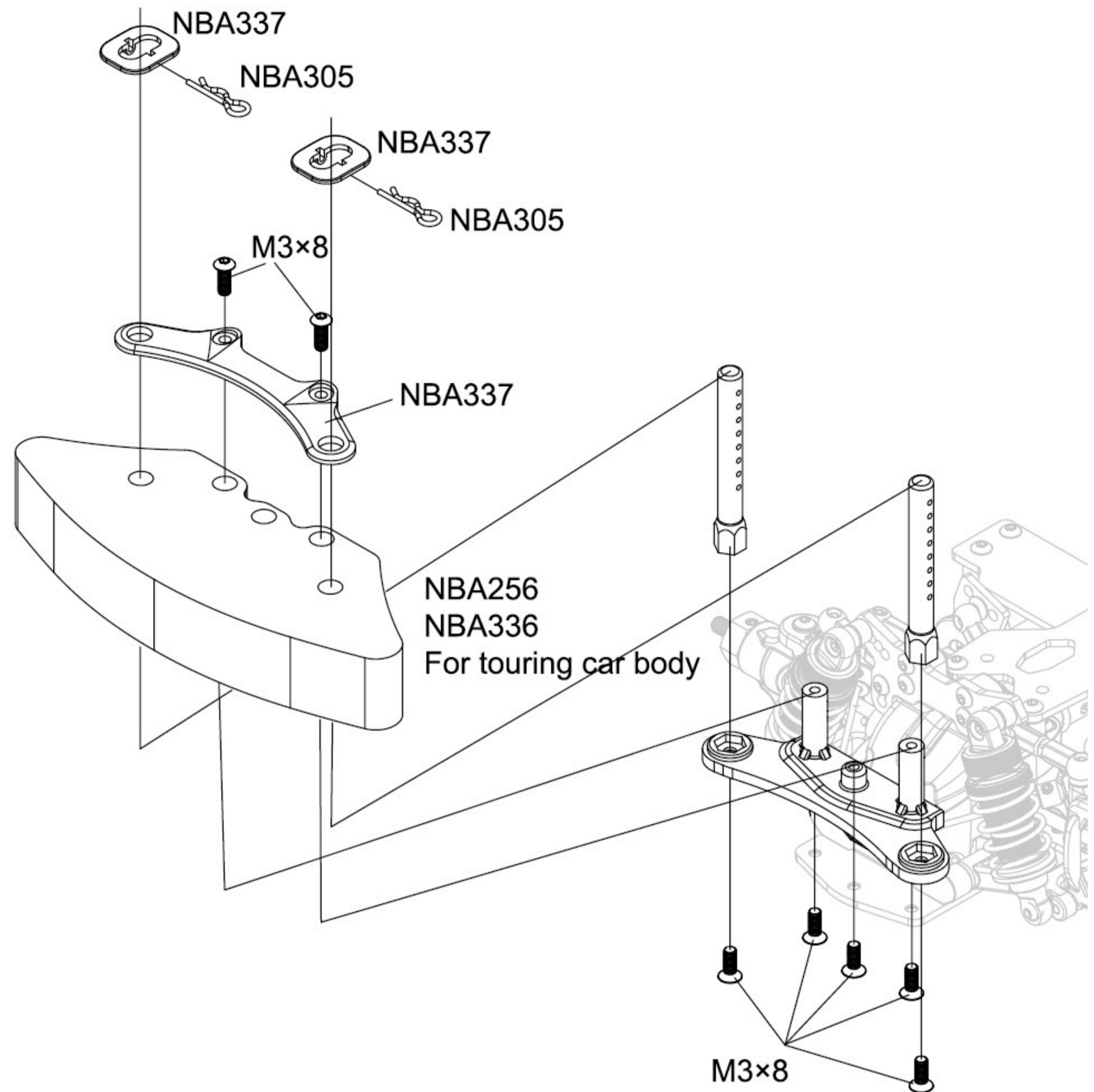

OP

Option Parts Assembly Manual

-  X2
NBA283
M3×10mm
-  X4
NBA282
M3×8mm
-  X4
NBA210
3×8mm
-  X2
NBA281
M3×6mm
-  X8
NBA305

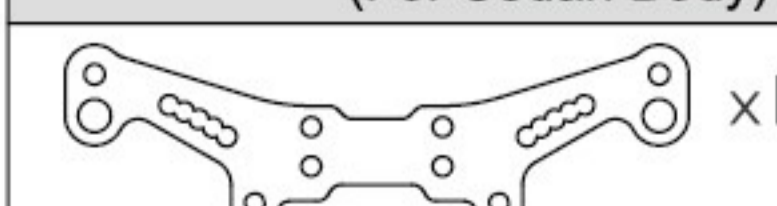
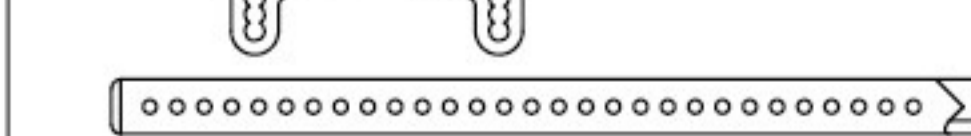
- NBA333** Rear Shock Tower (For Sedan Body)
 x1
 x2

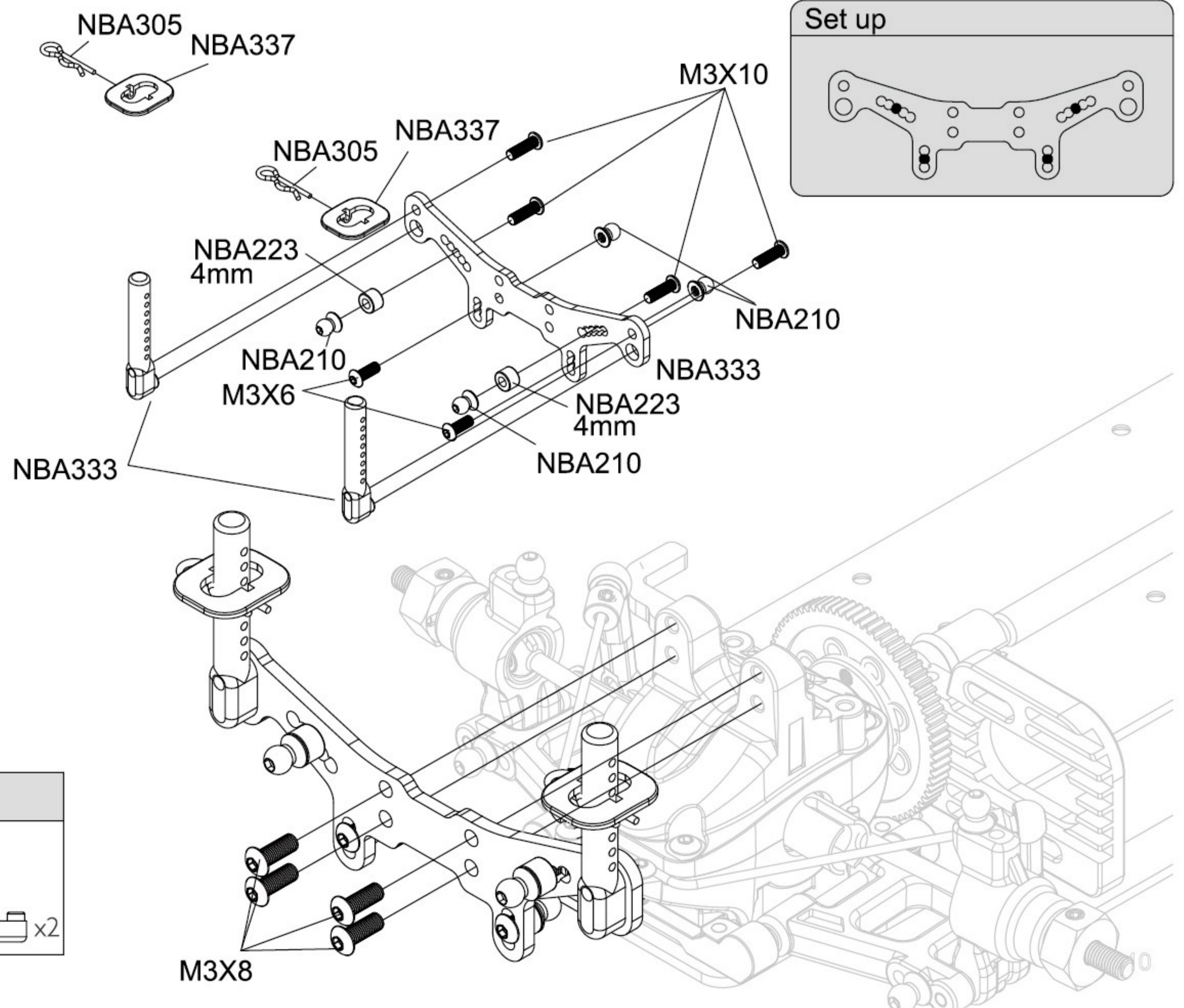

OP

Option Parts Assembly Manual



NBA285
M3×18mm



NBA283
M3×10mm



NBA288
M3×4mm



NBA281
M3×6mm

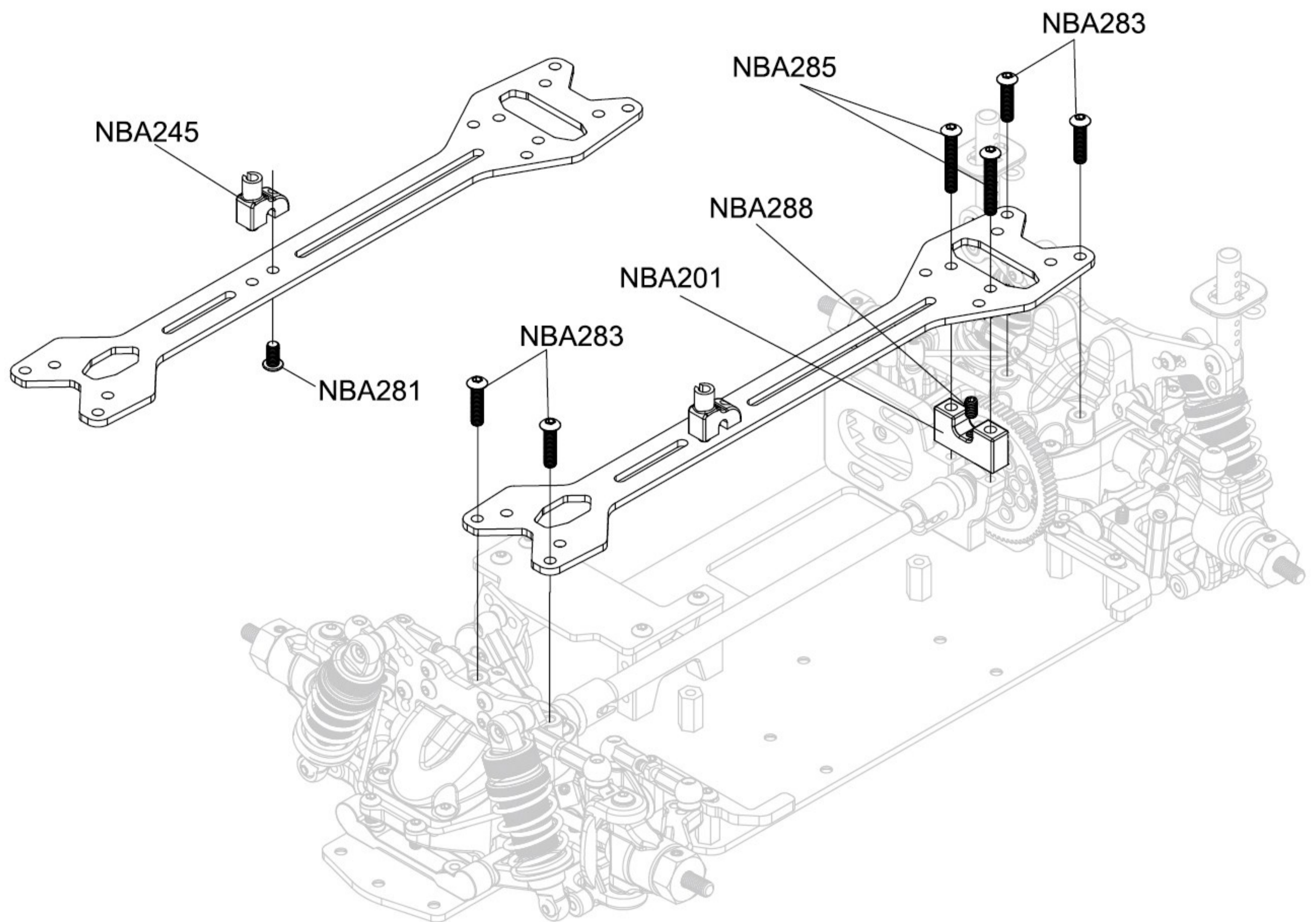

OP

Option Parts Assembly Manual



NBA311



NBA311
M3x12



NBA311
M3x3



NBA311
M3x6



NBA311

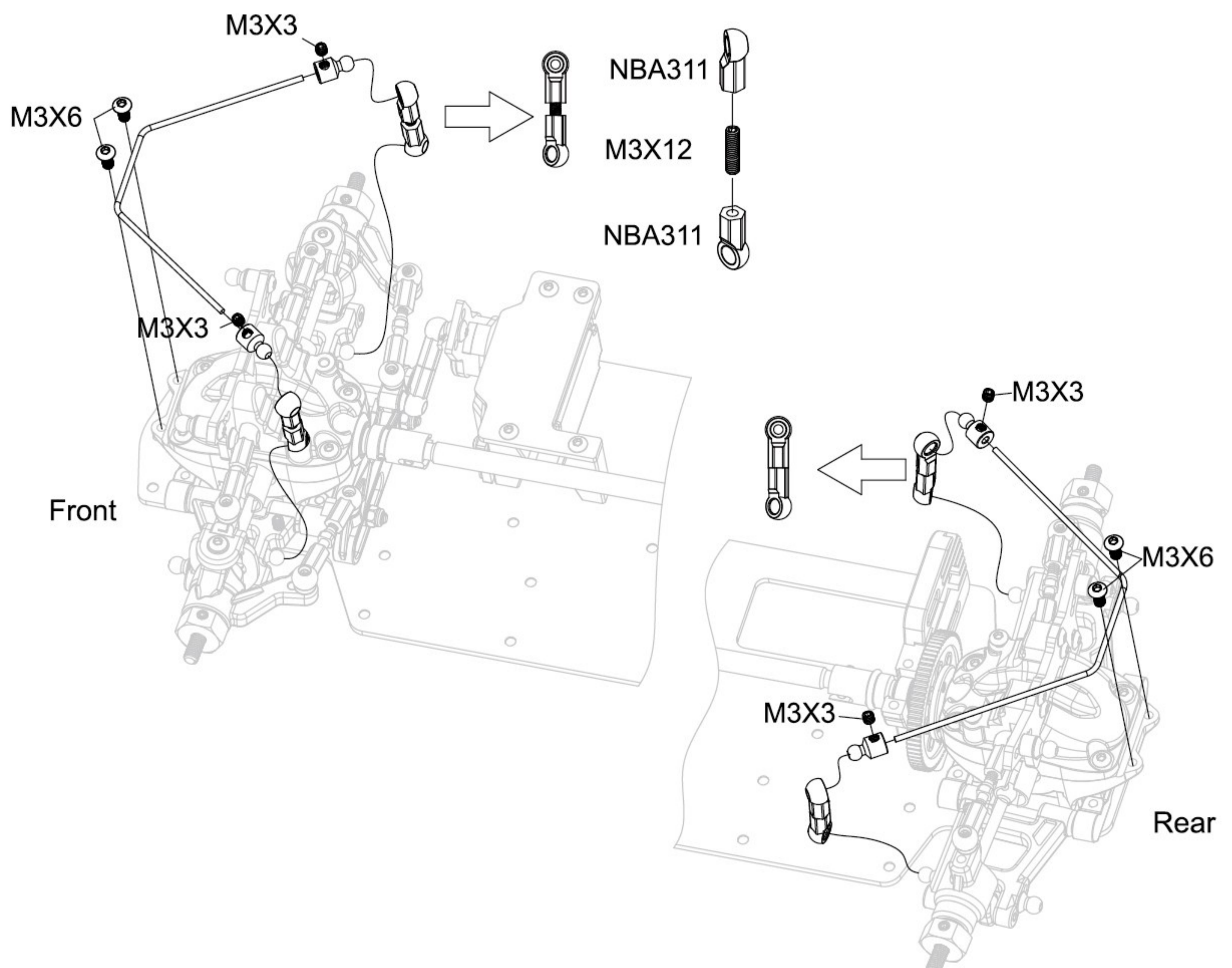

M210 / M210R M210R+ GEAR RATIO

SPUR GAER	BALL DIFF (40/17) M210	GEAR DIFF(42/17) M210R / M210R+
72	2.35	2.47
PINION GEAR	BALL DIFF GEAR RATIO	GERA DIFF GEAR RATIO
21	8.07	8.47
22	7.70	8.08
23	7.37	7.73
24	7.06	7.41
25	6.78	7.11
26	6.52	6.84
27	6.27	6.59
28	6.05	6.35
29	5.84	6.13
30	5.65	5.93
31	5.47	5.74
32	5.29	5.56
33	5.13	5.39
34	4.98	5.23
35	4.84	5.08
36	4.71	4.94
37	4.58	4.81
38	4.46	4.68
39	4.34	4.56
40	4.24	4.45
41	4.13	4.34
42	4.03	4.23
43	3.94	4.14
44	3.85	4.04

M210 RALLY GEAR RATIO

SPUR GAER	BALL DIFF (40/17)	GEAR DIFF(42/17)
68	2.35	2.47
PINION GEAR	BALL DIFF GEAR RATIO	GERA DIFF GEAR RATIO
25	6.40	6.72
26	6.15	6.46
27	5.93	6.22
28	5.71	6.00
29	5.52	5.79
30	5.33	5.60
31	5.16	5.42
32	5.00	5.25
33	4.85	5.09
34	4.71	4.94
35	4.57	4.80
36	4.44	4.67
37	4.32	4.54
38	4.21	4.42
39	4.10	4.31
40	4.00	4.20
41	3.90	4.10
42	3.81	4.00
43	3.72	3.91
44	3.64	3.82
45	3.56	3.73
46	3.48	3.65

Radio system instruction manual download



3CH - 91803G



4CH - 91804G

NBA201 Motor Mount

x1 x1

NBA209 Steering Bolt

x2

NBA210 4.8x6 mm Ball Stud

x10

NBA221 Shock shafts

x8 x4

NBA222 Shock Body(Aluminum)

x2

NBA230 Gear Differential

x2 x3

NBA202 Universal Shafts

x2

NBA211 Pivot Ball Stud

x10

NBA212 steering Bush

x4

NBA223 Shock Parts

x2 x2
x2 x2
x2 x2
x2 x2

NBA231 Gear Diff Case

x1 x4

NBA232 42T Bevel Gear (Metal)

x1 x4

NBA203 Center Drive Shaft (210mm Chassis)

x1

NBA213 12MM Hex Hub

x4 x4

NBA224 Plastic Shock

x4 x4
x4 x4
x4 x4

NBA233 Gear Diff Cup Joint

x2

NBA234 Gear Diff Oring

x4

NBA204 Drive Shaft And Spur Gear Hub (For Ball Diff)

x1 x1

NBA214 Suspension Shaft Set

x4
x2 x2

NBA225 Shock spring(1.2X22mm)Blue-Hard

x4

NBA235 Gear Diff Bevel Gear Set

x6 x2
x2 x1
x2 x2
x2

NBA205 Drive Shaft And Spur Gear Hub (For Gear Diff)

x1 x1

NBA215 39T-48P Pinon Gear (Aluminum)

x1 x1

NBA216 31T-48P Pinon Gear(Metal)

x1 x1

NBA226 Shock spring (1.2X22mm)Yellow-Medium

x4

NBA236 Ball Diff Parts Set

x1 x1 x1
x2 x12 x1

NBA206 Servo Mount Set

x1 x1 x1
x8 x2

NBA217 31T-48P Pinon Gear (Aluminum)

x1 x1

NBA218 27T-48P Pinon Gear (Metal)

x1 x1

NBA227 Shock spring (1.2X22mm) Red-Soft

x4

NBA237 Diff Ball (3/32)

x12

NBA238 Ball Diff Screw Set

x1 x1

NBA207 17T Metal Bevel Gear(Gear Diff)

x2
x2

NBA219 Shock Parts(O-rings)

x4 x8
x4 x4

NBA228 Shock Set(Plastic)

x4
x4

NBA239 Ball Diff Shim

x2

NBA240 Thrust Bearing

x2

NBA208 Turnbuckle Set (M3x12 /M3x19)

x2 x5

NBA220 Shock Body sets(Aluminum)

x2 x2
x2 x2

NBA229 Shock Set(Aluminum)

x4

NBA241 Diff gears(Ball Diff)

x1 x1

NBA242 Diff O-rings(Ball Diff)

x4

NBA243 Ball Diff cup joint (Plastic)

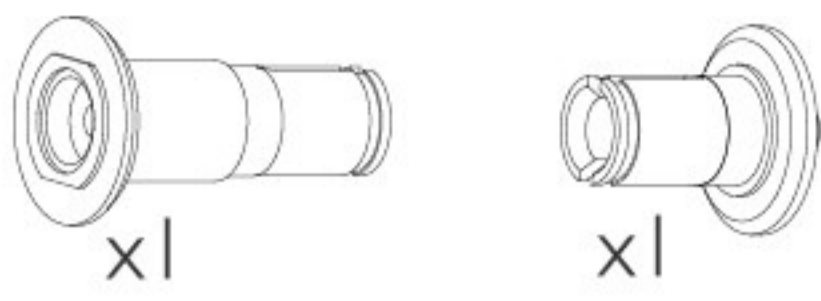

x1 x1

NBA254 Servo Saver

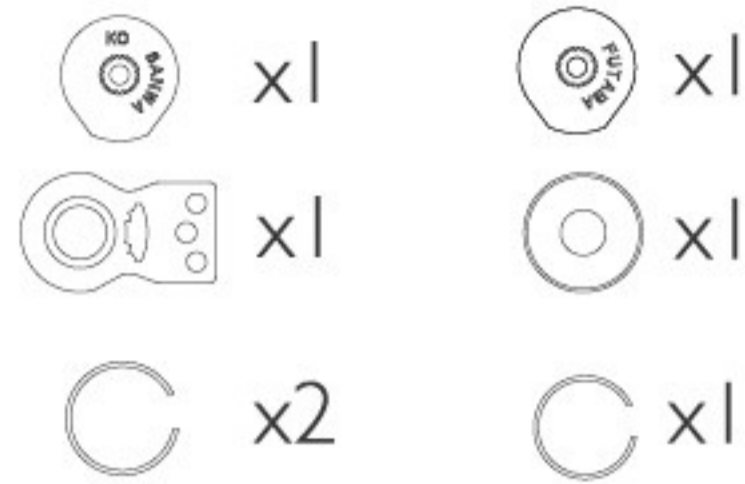

x1 x1
x1 x1
x2 x1

NBA263 8 Spoke Wheel +4mm (Silver)

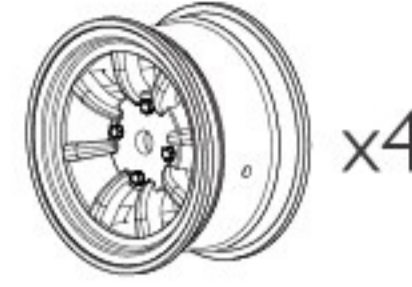

x4

NBA271 Main Chassis

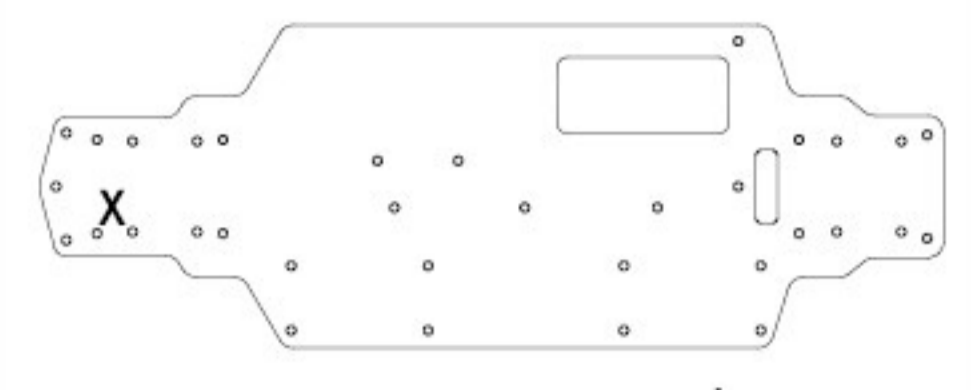

x1

NBA244 Ball Diff cup joint (Metal)

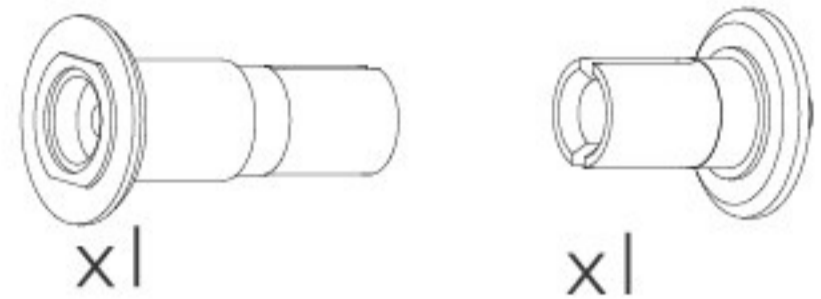

x1 x1

NBA255 Cup Jiont



x3
x2
x2

NBA264 8 Spoke Wheel +4mm (Gray)

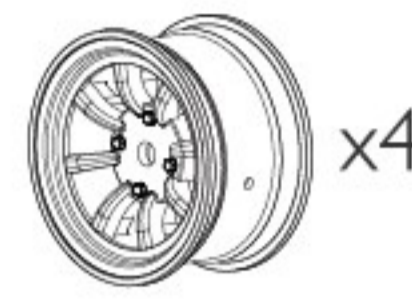

x4

NBA272 Upper Deck



x1

NBA245 Front Bumper Hold And Body Mount

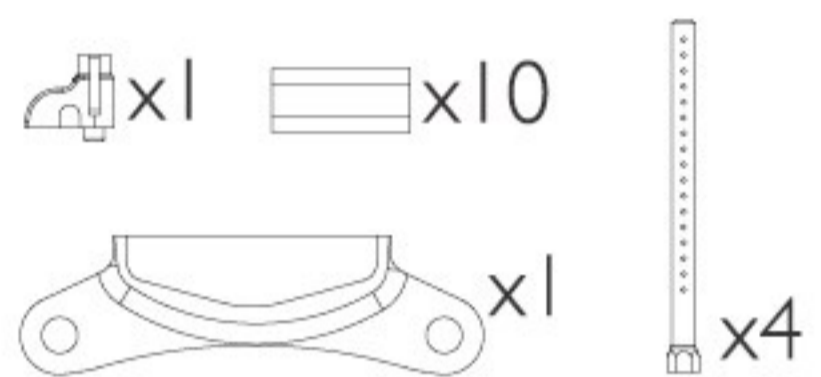

x1 x10
x1 x4

NBA256 Bumper For Sedan Body



x1

NBA265 8 Spoke Wheel +4mm (Black)

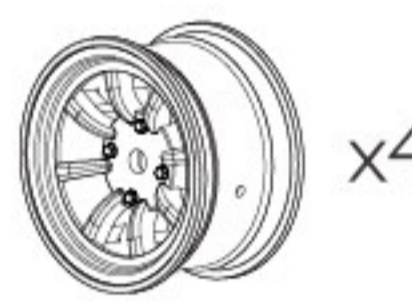

x4

NBA274 Battery Holder



x2

NBA246 Front Hub Carrier L/R



x1 x1

NBA257 Bumper For Hatchback Body



x1

NBA266 10 Spoke Wheel +1mm (Silver)

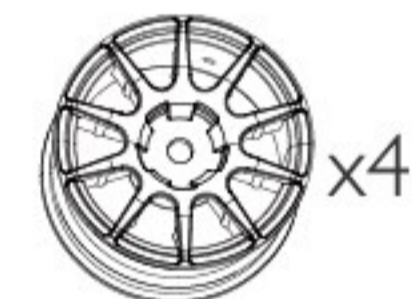

x4

NBA276 Servo Plate

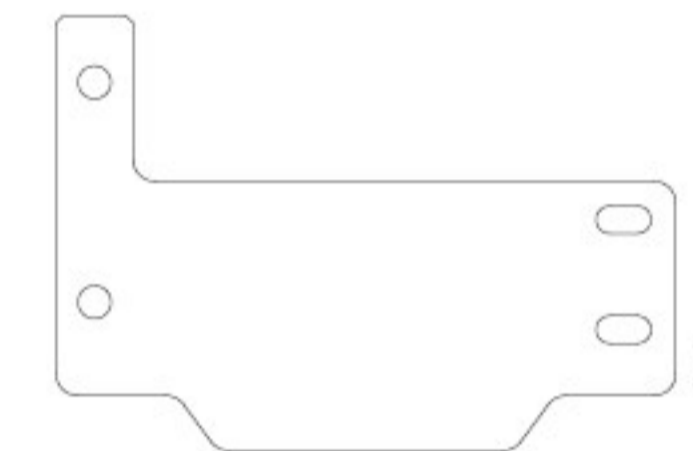

x1

NBA247 Ball End (4.8mm)



x8 x2

NBA248 Suspension Mount Parts

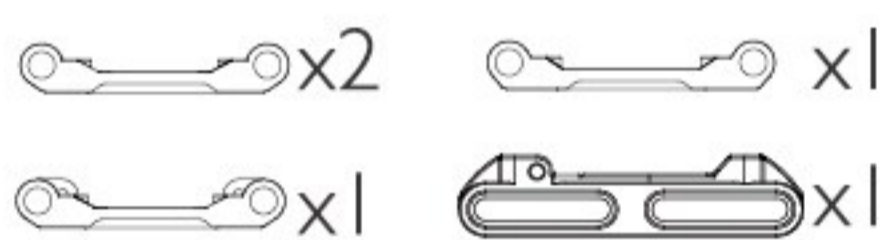

x2 x1
x1 x1

NBA258 Battery Strap



x2

NBA267 10 Spoke Wheel +1mm (Gray)

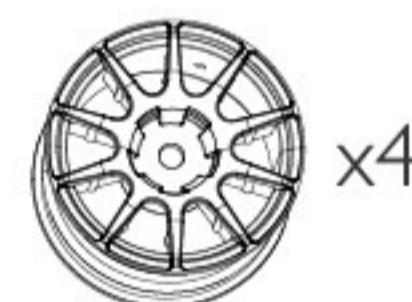

x4

NBA277 Bumper Plate (For Hatchback Body)



x1

NBA259 Antenna Pipe



x1 x1

NBA278 Bumper Plate (For Sedan Body)



x1

NBA249 Gear box

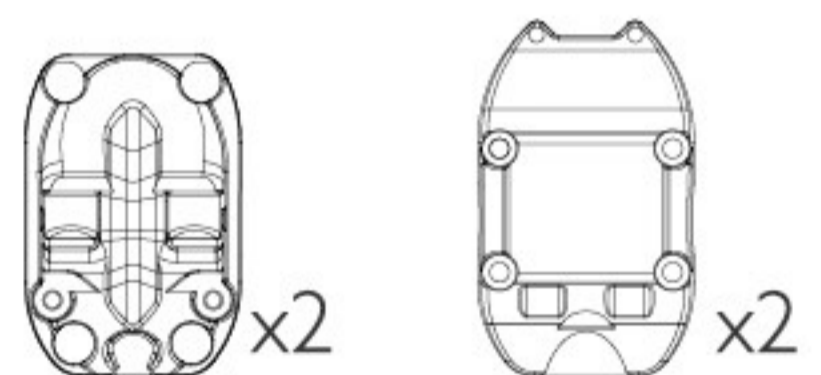

x2 x2

NBA260 8 Spoke Wheel +1mm (Silver)

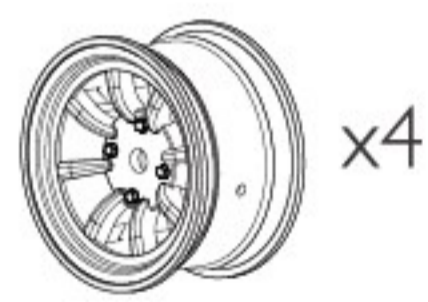

x4

NBA268 10 Spoke Wheel +4mm (Silver)

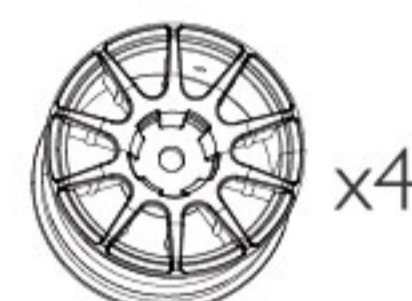

x4

NBA279 Screw Set-FH M3x6



x10

NBA250 Arms Set (F and R)

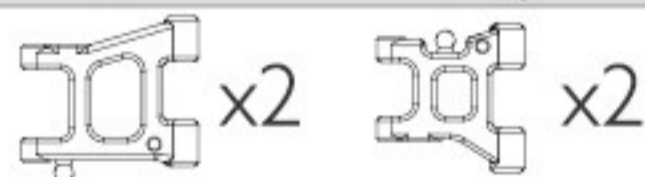

x2 x2

NBA261 8 Spoke Wheel +1mm (Gray)

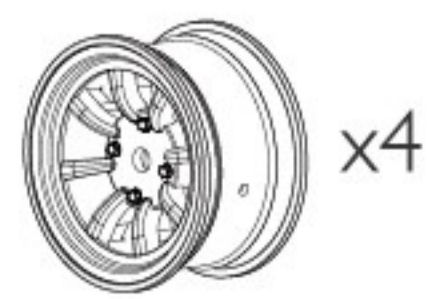

x4

NBA269 10 Spoke Wheel +4mm (Gray)

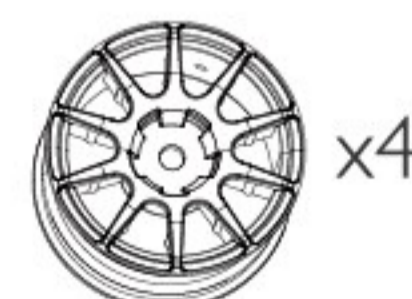

x4

NBA281 Screw Set-BH M3x6



x10

NBA251 Hub carrier



x2 x2

NBA282 Screw Set-BH M3x8



x10

NBA252 Spur Gear 72T



x1

NBA262 8 Spoke Wheel +1mm (Black)

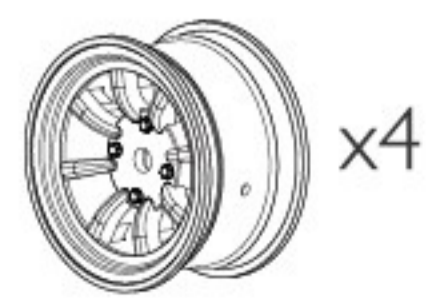

x4

NBA270 Tires

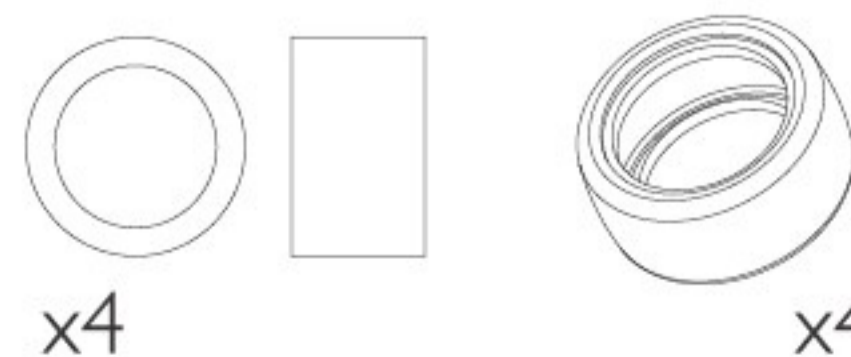

x4 x4

NBA283 Screw Set-BH M3x10



x10

NBA253 Hex Hub (5MM)



x4 x4

NBA284 Screw Set-BH M3x12



x10

M210 PART LIST

NBA285 Screw Set-BH M3x18



NBA305 Body pinS



NBA319 10 Spoke Wheel +1mm (Black)

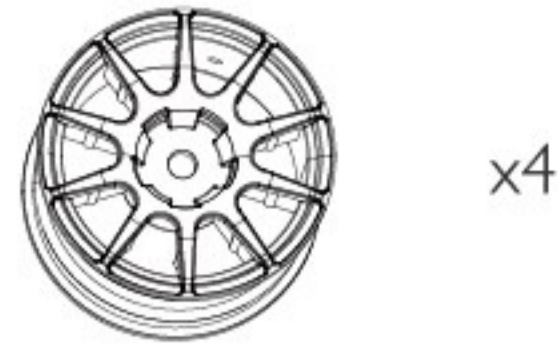

NBA329 M-Drift Tires + Wheels 10 Spoke +1mm (Black)

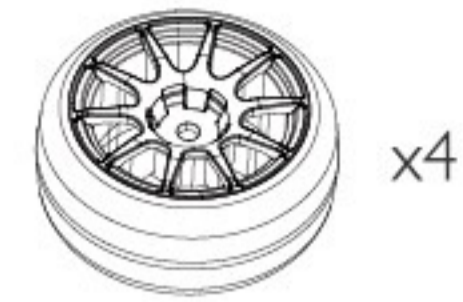

NBA286 Screw Set-FH M2x8



NBA306 O-Ring



NBA320 10 Spoke Wheel +4mm (Black)

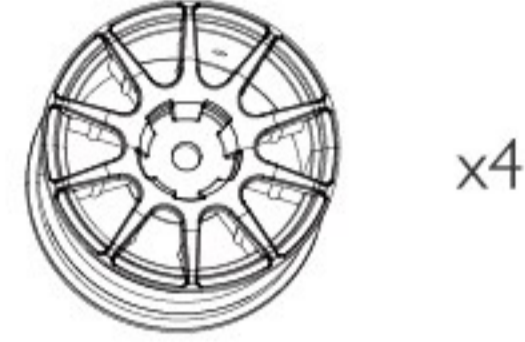

NBA330 M-Rally Tires + Wheels 10 Spoke White +1mm (4PCS)



NBA287 Set Screw M3x3



NBA307 Washer(11*14*0.2mm)



NBA288 Set Screw M3x4



NBA308 Differential(Plastic)

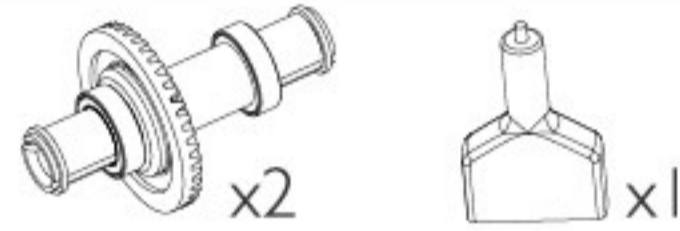

NBA331 M-Rally Tires (4PCS)



NBA289 Set Screw M3x8



NBA309 Differential(Metal)



NBA321 Solid Axle(40T/17T Plastic)

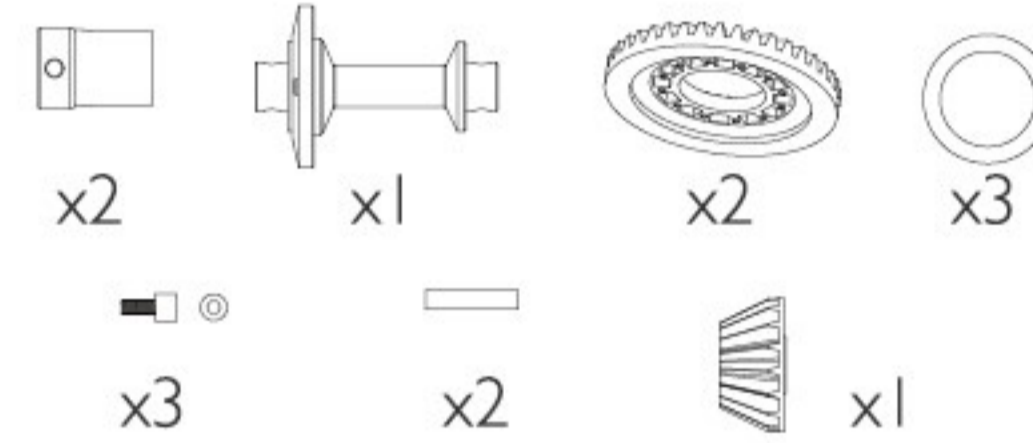

NBA332 Strong Ball End 4.8mm (4PCS)

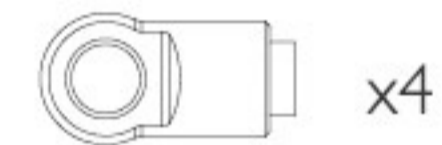

NBA291 Set Screw M3x12

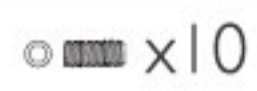

NBA310 Gear Differential Set

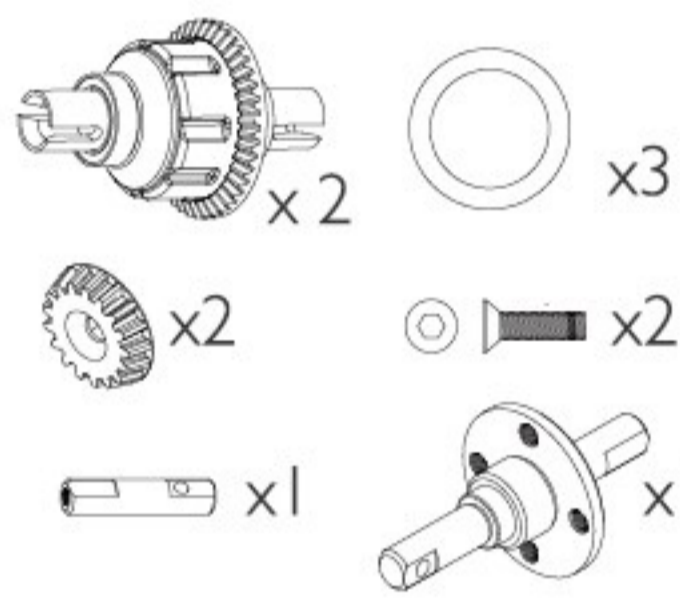

NBA322 Plastic 40T/17T Bevel Gear (For Solid Axle)

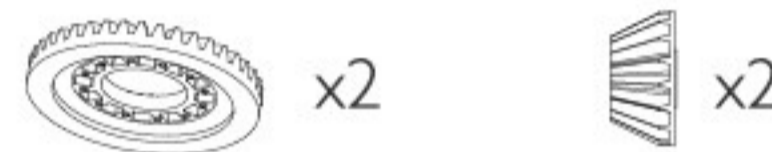

NBA333 Rear Shock Tower (For Sedan Body)

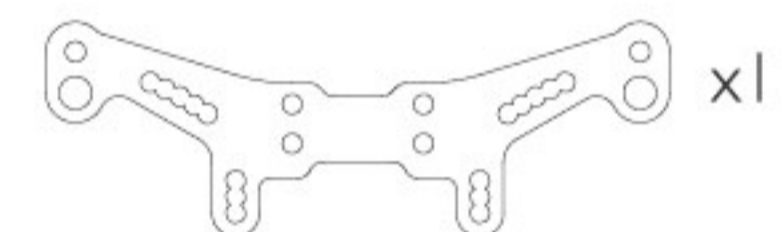

NBA292 Set Screw M3x18



NBA311 Sway Bar

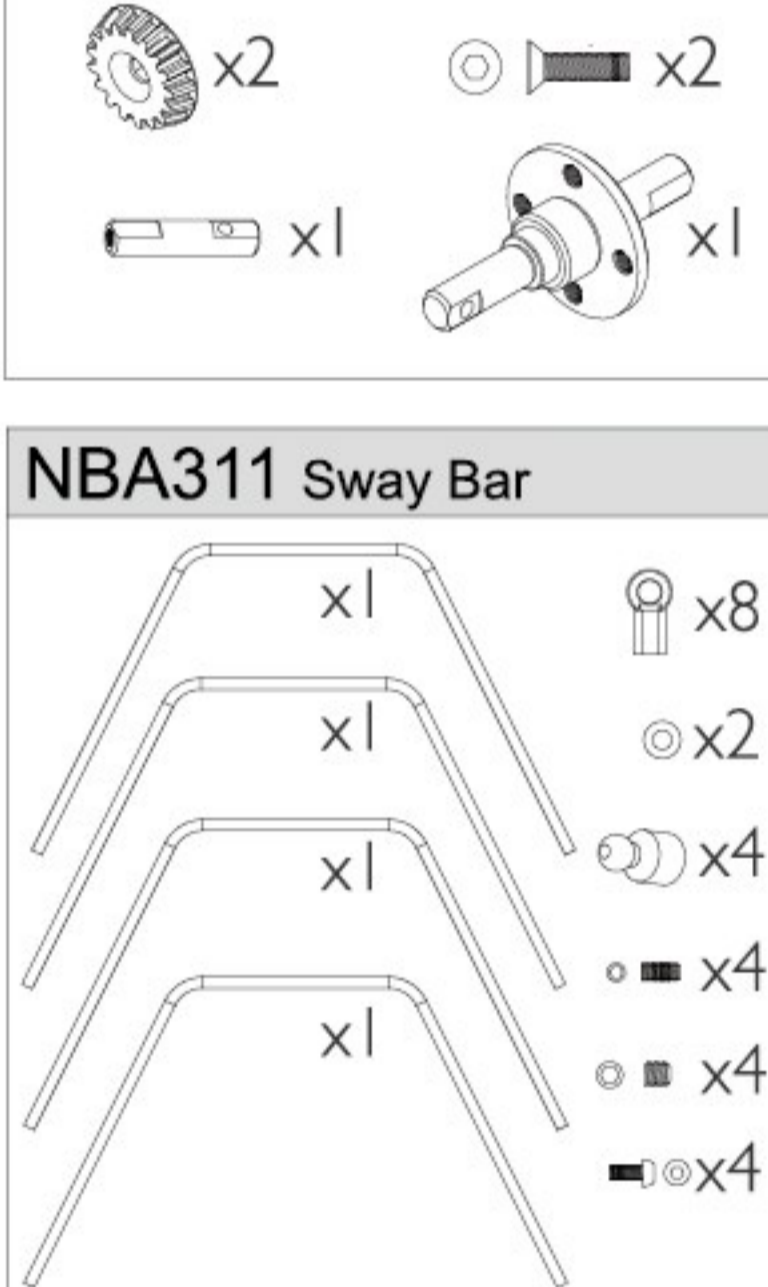

NBA323 Solid Axle(42T/17T Metal)

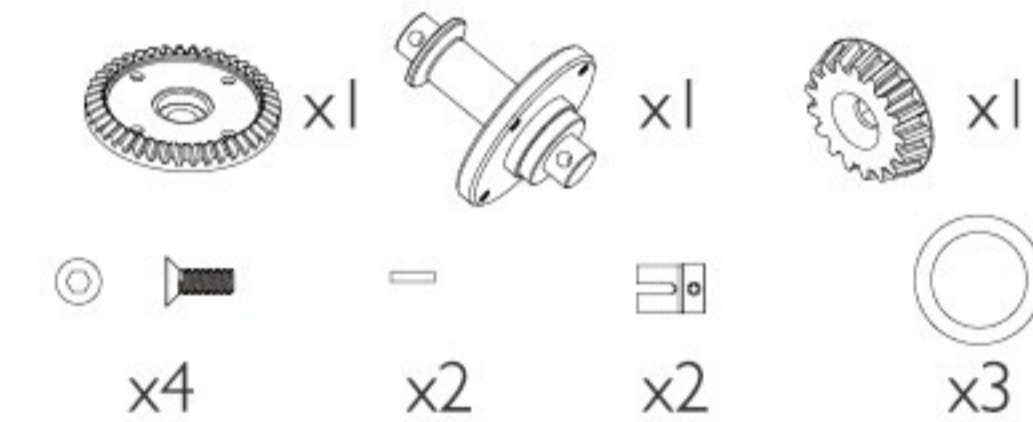

NBA334 Strong Ball End 4.8mm (Long 4PCS)

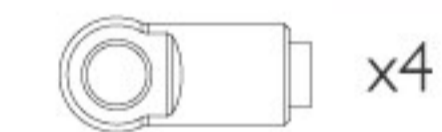

NBA294 M3 Nut



NBA312 Fan Holder (For 30mm Fan)

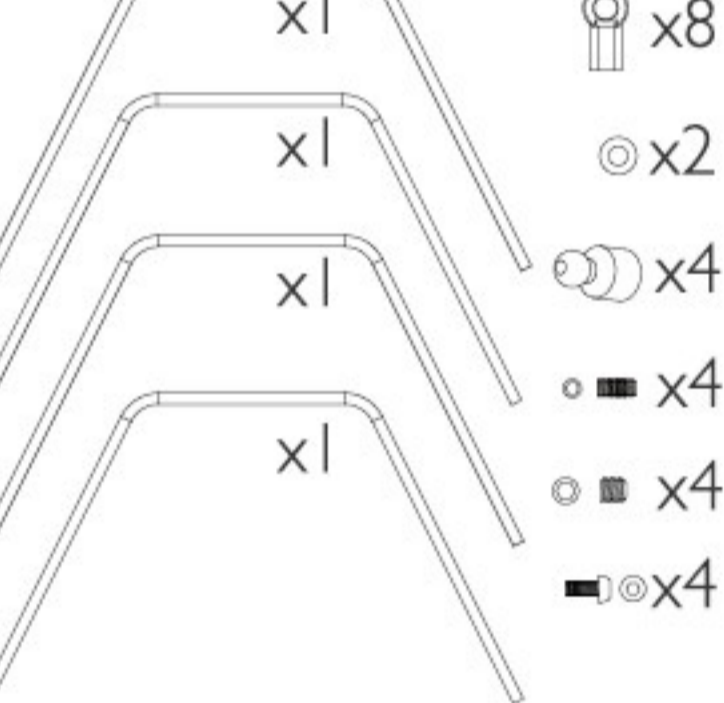

NBA324 225mm Chassis Kit

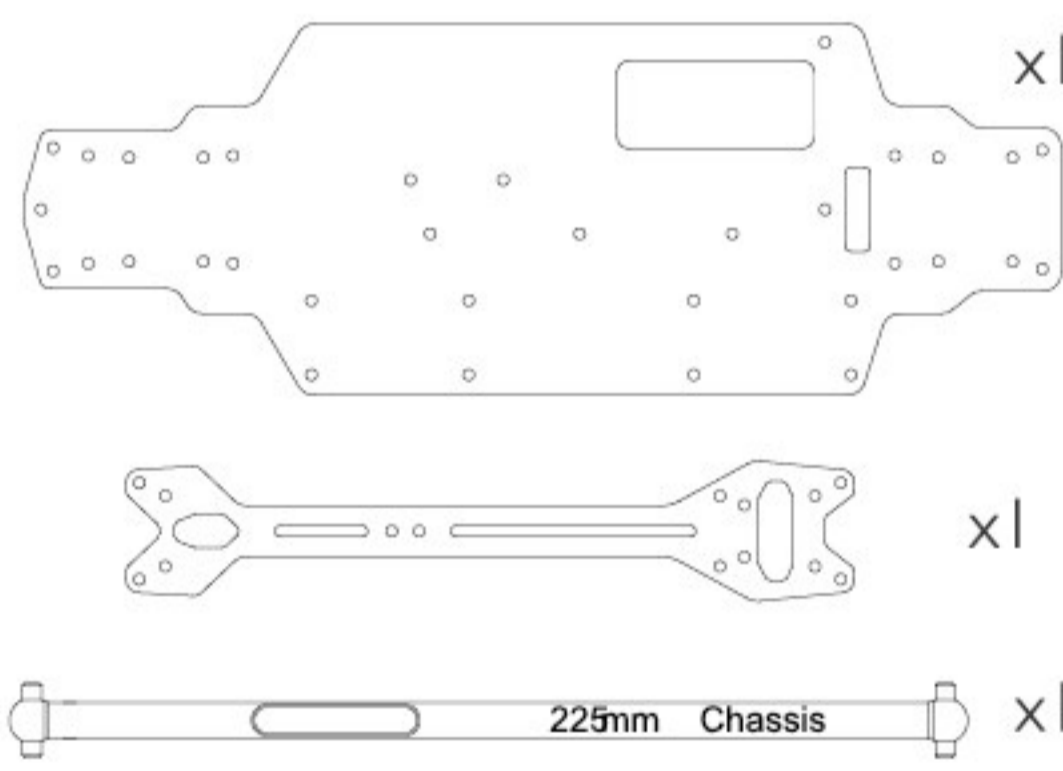

NBA335 Shock spring (1.2X22mm) Green-Soft



NBA295 M4 Nut



NBA313 Pivot Block (ALUMINUM)3°



NBA325 42T Metal Bevel Gear (for Solid Axle)

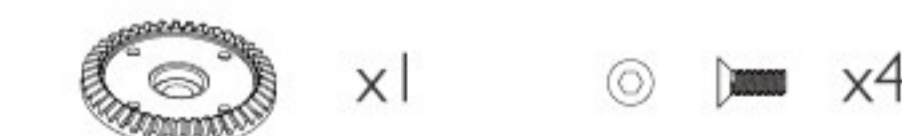

NBA336 Bumper For Touring Car Body



NBA296 Bearing 3x6x2.5



NBA314 Pivot Block (ALUMINUM) 0°



NBA326 Metal Center Cup Joint (For Ball Diff)



NBA337 Bumper Plate & Body Post Spacer



NBA297 Bearing 5*8*2.5



NBA315 Pivot Block (ALUMINUM) 2.5°



NBA327 Metal Center Cup Joint (For Gear Diff)



NBA338 Pivot Block (ALUMINUM) 2.0°



NBA298 Bearing 5x10x4



NBA316 Pivot Block (ALUMINUM)



NBA328 M-Drift Tires + Wheels 8 Spoke +1mm (Black)



NBA339 ALUMINUM REAR HUB

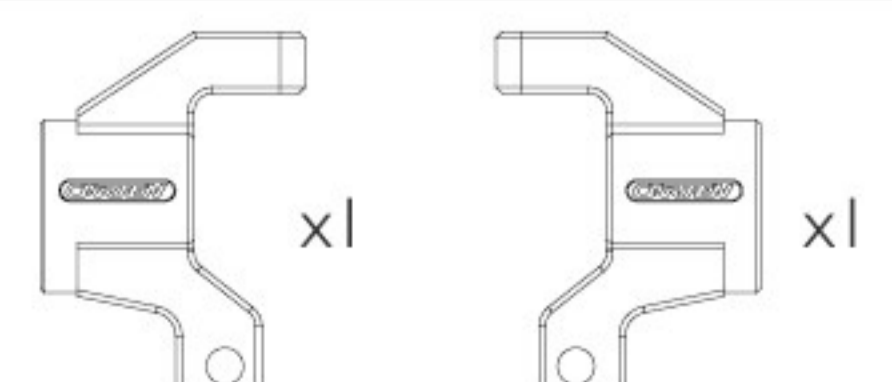

NBA299 Bearing 10x15x4



NBA300 Spacer Set 3x6x2.5



NBA301 Washer(3*6.5*0.5mm)



NBA302 Washer(3*8*0.5mm)



NBA303 E-Clip



NBA304 Pin2X10



NBA317 Steering Mount (ALUMINUM)



NBA318 Aluminum Hex 5.5 x 10mm



NBA340 Aluminum C Hub(L/R)



NBA341 Aluminum Steering Blocks



NBA342 Body Post (Rear)



NBA343 12mm Hex Hub (6mm)



NBA344 12mm Hex Hub (7mm)



NBA345 Center Drive Shaft (225 mm Chassis)

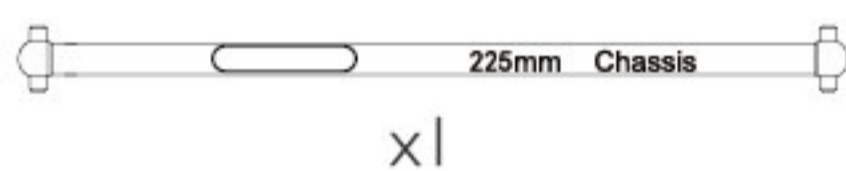

NBA346 ALUMINUM SPACER 3X6X0.5



NBA347 ALUMINUM SPACER 3X6X1.0



NBA348 ALUMINUM SPACER 3X6X2.0



NBA349 ALUMINUM SPACER 3X6X3.0



NBA350 ALUMINUM SPACER 3X6X4.0



NBA351 M3 Nylon Lock Nut



NBA352 M4 Nylon Lock Nut



NBA353 M4 Serrated Lock Nut



NBA354 Solid Axle Steel Cup Joint



NBA355 23T Brushed Motor



NBA356 Extended Body Post(6mm)



NBA357 Gear Diff Cup Joint (Heavy Duty)



NBA358 Solid Axle Steel Cup Joint (Heavy Duty)



NBA359 M210 Rally chassis AL-7075

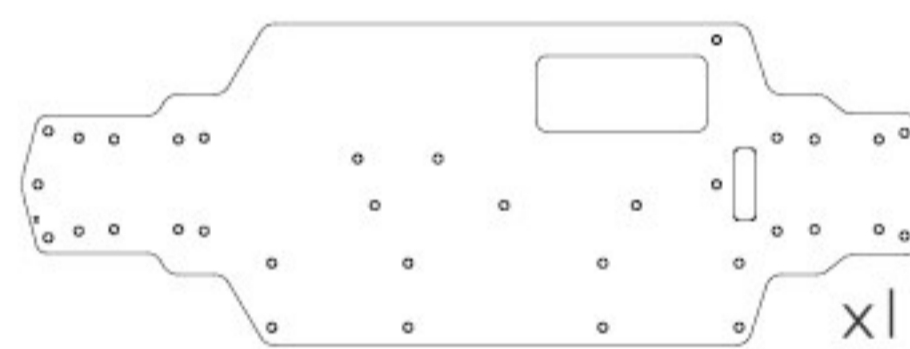

NBA360 Spur Gear 68T (Heavy Duty Steel)

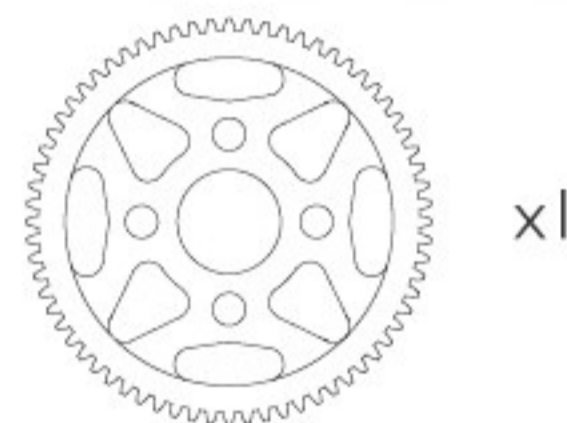

NBA361 CVD Pin



NBA362 Shock Spacer



NBA363 Shock Pistons-3H1.2



NBA364 Shock Pistons-4H1.1



NBA365 225mm Chassis

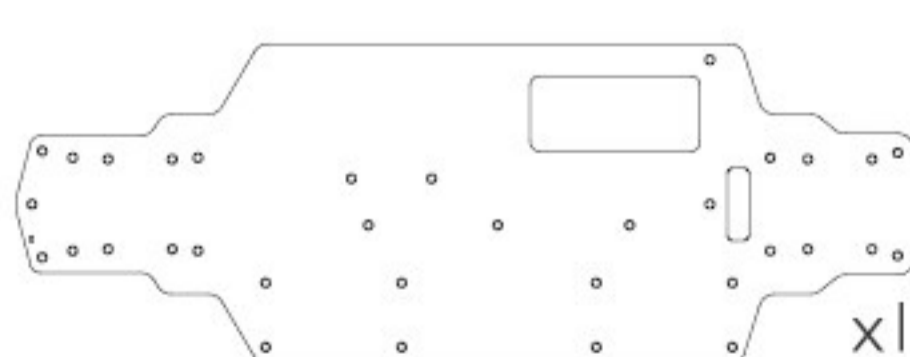

NBA366 225mm Upper Deck



NBA367 M-Drift Tires (4PCS)



NBA368 CARTEN 60A Brushed ESC



NBA369 Battery holder



NBA370 Bevel Gear Set





M **M210** **M-CHASSIS**
M **M210R** 1/10 EP RC M-Chassis Kit
RC CAR

